



ASSEMBLY MANUAL

CONTENTS

1. SCOPE OF THIS ASSEMBLY MANUAL	3
2. GENERAL NOTES ABOUT ASSEMBLY	4
3. TOOLS AND TORQUE SPECS	5
4. HOUSING AND HOSE LENGTH RECOMMENDATION	6
5. RIM BRAKE: INSTALLATION AND HOUSING ROUTING	7
6. DISC BRAKE: INSTALLATION AND HOSE ROUTING	12
7. ELECTRONIC GROUPSET (DI2) INSTALLATION AND CABLE ROUTING	17
8. MECHANICAL GROUPSET INSTALLATION	22
9. INTEGRATED HANDLEBAR (TALON ULTRA) ROUTING (ELECTRONIC DI2)	25
10. INTEGRATED HANDLEBAR (TALON ULTRA) ROUTING (MECHANICAL)	29
11. BRAKE CABLE INSTALLATION (INTEGRATED HANDLEBAR)	35
12. HEADSET ADJUSTING	44
13. STEM AND BAR INSTALLATION AND ROUTING (FOUR CONFIGURATIONS)	48
14. FINAL CHECKS	51

1. SCOPE OF THIS ASSEMBLY MANUAL

- 1.1 This manual is intended as a guide for the assembly of the Dogma F12 and Dogma F12 Disk from a frame kit to a complete bike.
- 1.2 Due to the high degree of complexity of the Dogma F12 and Dogma F12 Disk this manual is intended for expert mechanics of Authorized Pinarello Dealers.
- 1.3 Please utilize Authorized Pinarello Dealers for assembly, service, repairs or maintenance performed on the Pinarello Dogma F12 and Dogma F12 Disk.
- 1.4 The following instructions for electronic groupsets are focused for Shimano Di2 wiring. Sram eTAP or Campagnolo EPS may be different from the given instruction.
- 1.5 In the downloads section of www.pinarello.com you can download Dogma F12 and Dogma F12 Disk assembling video as support for this manual. As well as a digital version of this document.

2. GENERAL NOTES ABOUT ASSEMBLY

- 2.1** Before assembly inspect all components (frame, fork, seatpost, handlebar, headset top cap and spacers) to ensure that there aren't any sharp edges, burrs or cracks.
- 2.2** In the case of any crack, DO NOT continue assembly and immediately contact the Pinarello Customer Service.
- 2.3** All edges of the handlebar, stem, top cap and spacers in contact with the steerer tube should be rounded out to eliminate stress points.
- 2.4** Do not drill, remove parts or modify the frame components in any way. Not following this warning could result in injury or death.
- 2.5** Do not install incompatible components. Use of other components may compromise the integrity of the assembly.

3. TOOLS AND TORQUE SPECS

3.1 Use the proper tightening torques, it is essential for the correct function and to avoid loosening or structural damages. In certain cases tightening torques ensure mechanical couplings, in other cases they prevent loosening. Depending on the application, the threads should be greased or treated with thread-lockers. Refer to the chart below for the proper torque to be applied and for the treatment.

Suggested thread-lockers are:

- Loctite 222
- Arexons System 52A22

To lubricate threads never use lithium-based greases.

COMPONENT	TORQUE [Nm]	THREAD	TOOL
Seat Post: fixing clamp	4	Lubricated	Torx T15
Seat Post: saddle rail bolts	4 (front)	Lubricated	10 mm HEX key (front)
	8(rear)		5 mm Allen key (rear)
Stem: fork tube fixing bolt	6	Thread-locker	Torx T20
Expander: inside steerer tube	6	Lubricated	Allen key 6 mm
Cap on top of the stem	Preload: 2 Final: 6 (MAX)	Thread-locker	Allen key 5 mm
Bottle Cage	2	Thread-locker	Torx T25
BB Cable Guide	2	Thread-locker	Torx T20
Down Tube Cover	0.5	Thread-Locker	Allen key 2 mm
Talon Ultra Cover (rear)	0.5 (MAX)	Thread-Locker	Torx T10
Talon Ultra Cover (front)	w/o iTalon	1 (MAX)	Thread-Locker Torx T25
	w/ iTalon	3	

Use MOST Safe grip paste on the seat post before installing it. After first ride, and consistently thereafter, recheck the tightness of each bolt to ensure secure attachment of the components.

4. HOUSING AND HOSE LENGTH RECCOMENDATION

- 4.1 In order to properly assemble the Dogma F12 and Dogma F12 Disk we recommend using the following minimum housing and hose lengths, which will then be cut according to the frame and handlebar size.

	FRONT Brake	REAR Brake
RIM Brakes – minimum housing length [mm]	580	1250
DISC Brakes – minimum hose length [mm]	1000	1700

- 4.2 MECHANICAL GROUPSET:
- FRONT Derailleur housing length = 1000 mm
 - REAR Derailleur housing length = 1000 mm

5. RIM BRAKE: INSTALLATION AND HOUSING ROUTING

- 5.1 Assembly the Rear Brake (RB) on the frame. Only Direct Mount rim brakes are compatible.

ATTENTION! follow the brake OEM assembly instructions.

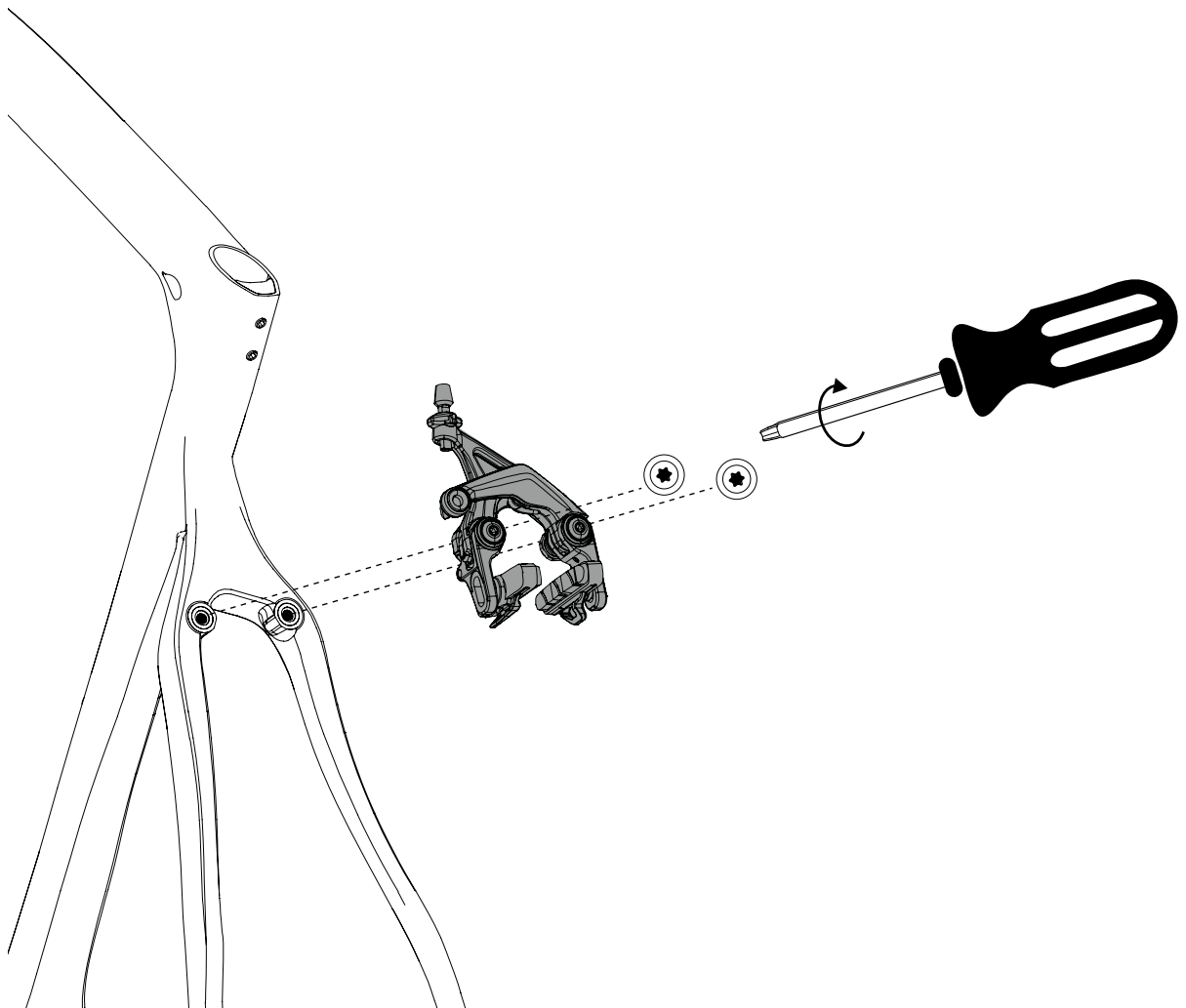

5. RIM BRAKE: INSTALLATION AND HOUSING ROUTING

- 5.2** Assembly the Front Brake (FB) on the fork. Only Direct Mount rim brakes are compatible.
ATTENTION! follow the brake OEM assembly instructions.

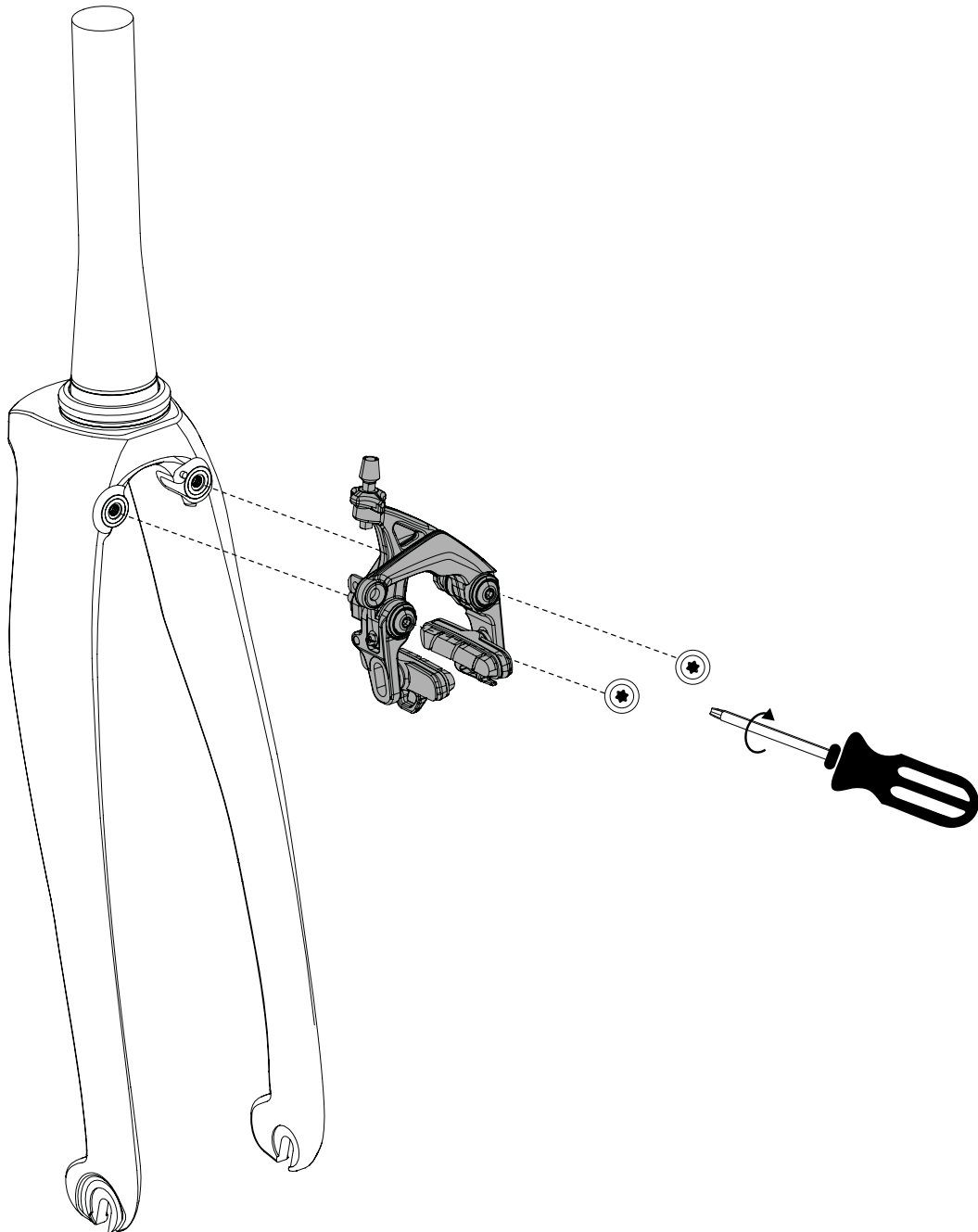

5. RIM BRAKE: INSTALLATION AND HOUSING ROUTING

- 5.3** Route the RB housing into the frame top tube, from the exit hole on the rear part of top tube to the head tube.
Refer to chapter "4. HOUSING AND HOSE LENGTH RECCOMENDATION" for the correct housing length.
- 5.4** Apply 40 cm foam sleeve on the RB housing and pull it into the top tube. Make sure to place the foam sleeve nearby the head tube.

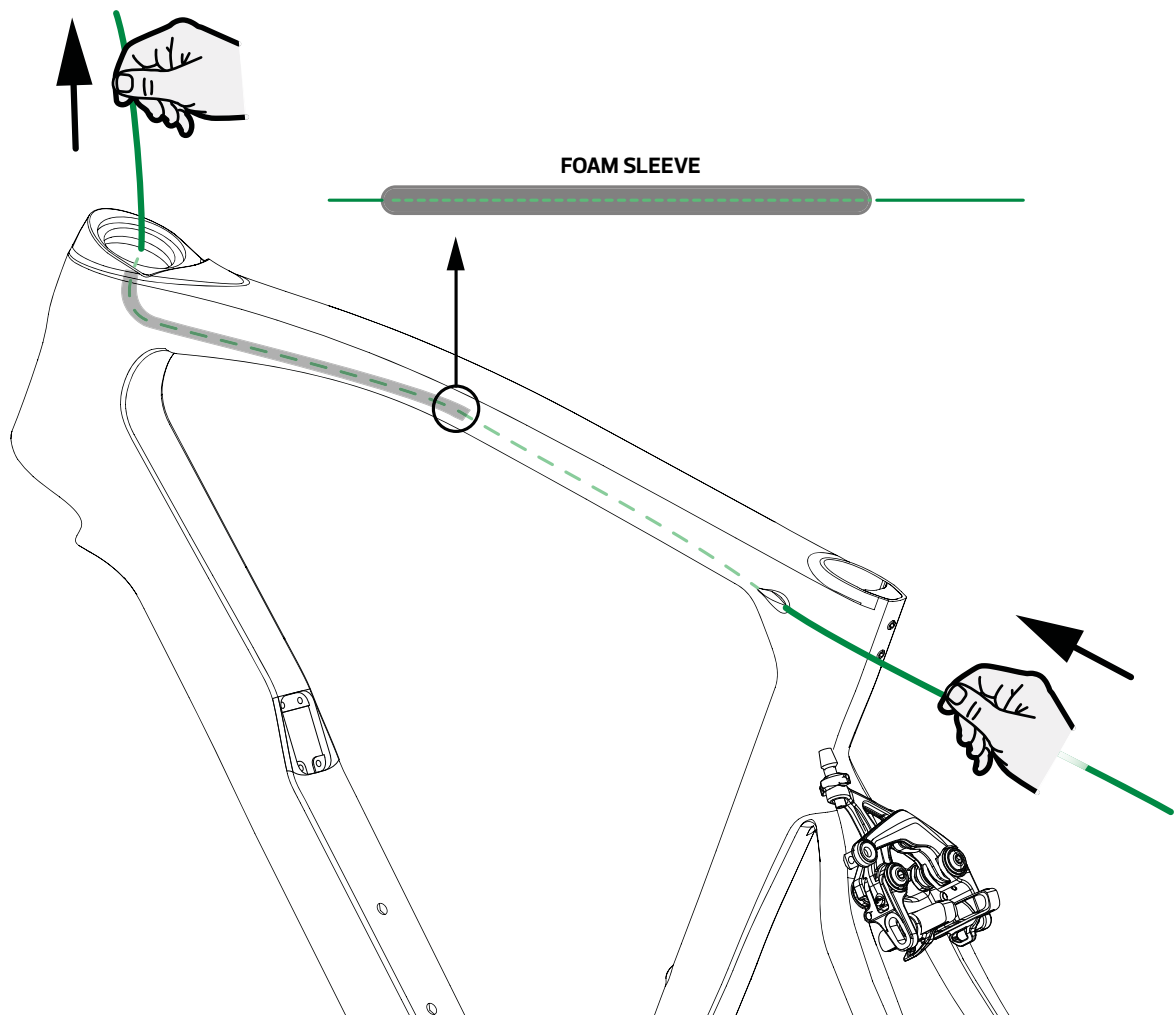

5. RIM BRAKE: INSTALLATION AND HOUSING ROUTING

5.5 Headset top cap assembly:

- Install the lower headset bearing (bearing 1" ½ and crown race) into the proper frame seat.
- ATTENTION! apply grease around the bearing frame seat.**
- Push the steerer tube up into the head tube. Use a proper support for the fork while installing.

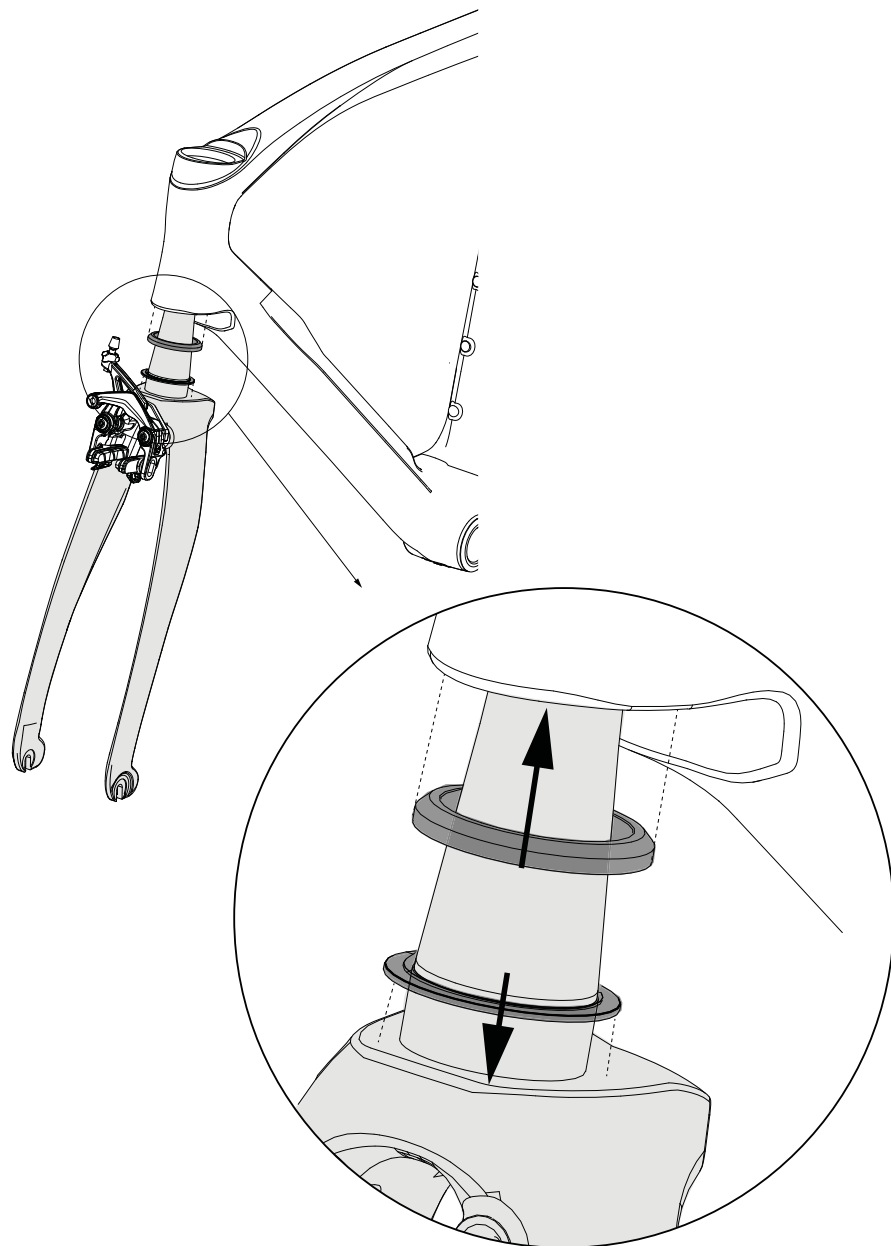

5. RIM BRAKE: INSTALLATION AND HOUSING ROUTING

- Install the upper bearing in its frame seat. Make sure to capture the RB housing between bearing and steerer tube.

ATTENTION! apply grease around the bearing frame seat.

- Install the compression ring.

ATTENTION:

• the cut on compression ring must be on the backward side.

• the RB housing must be on the right notch in the compression ring.

- Install the head set top cap. Make sure to keep the RB housing on the right notch in the headset top cap.

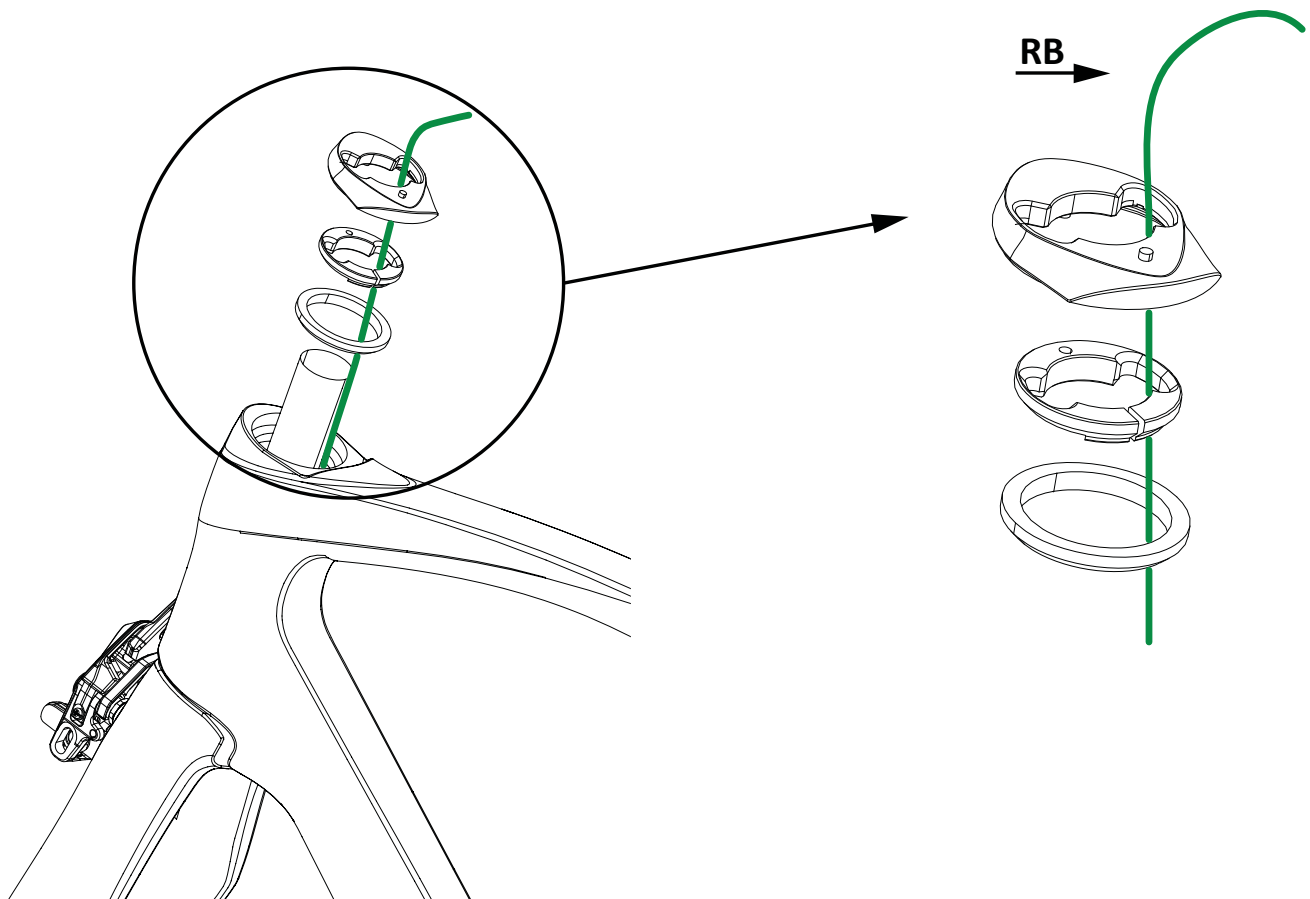

In case of Electronic groupset (Di2) go to chapter 7.

In case of Mechanical groupset go to chapter 8.

6. DISC BRAKE: INSTALLATION AND HOSE ROUTING

- 6.1** Route the RB hose from the left chainstay hole to the top tube. RB hose must route above the Bottom Bracket (BB) sleeve.

Refer to chapter "4. HOUSING AND HOSE LENGTH RECCOMENDATION" for the correct hose length.

ATTENTION! push the RB hose on the special clip located inside the frame in correspondence with the Down Tube (DT) opening. See figure below.

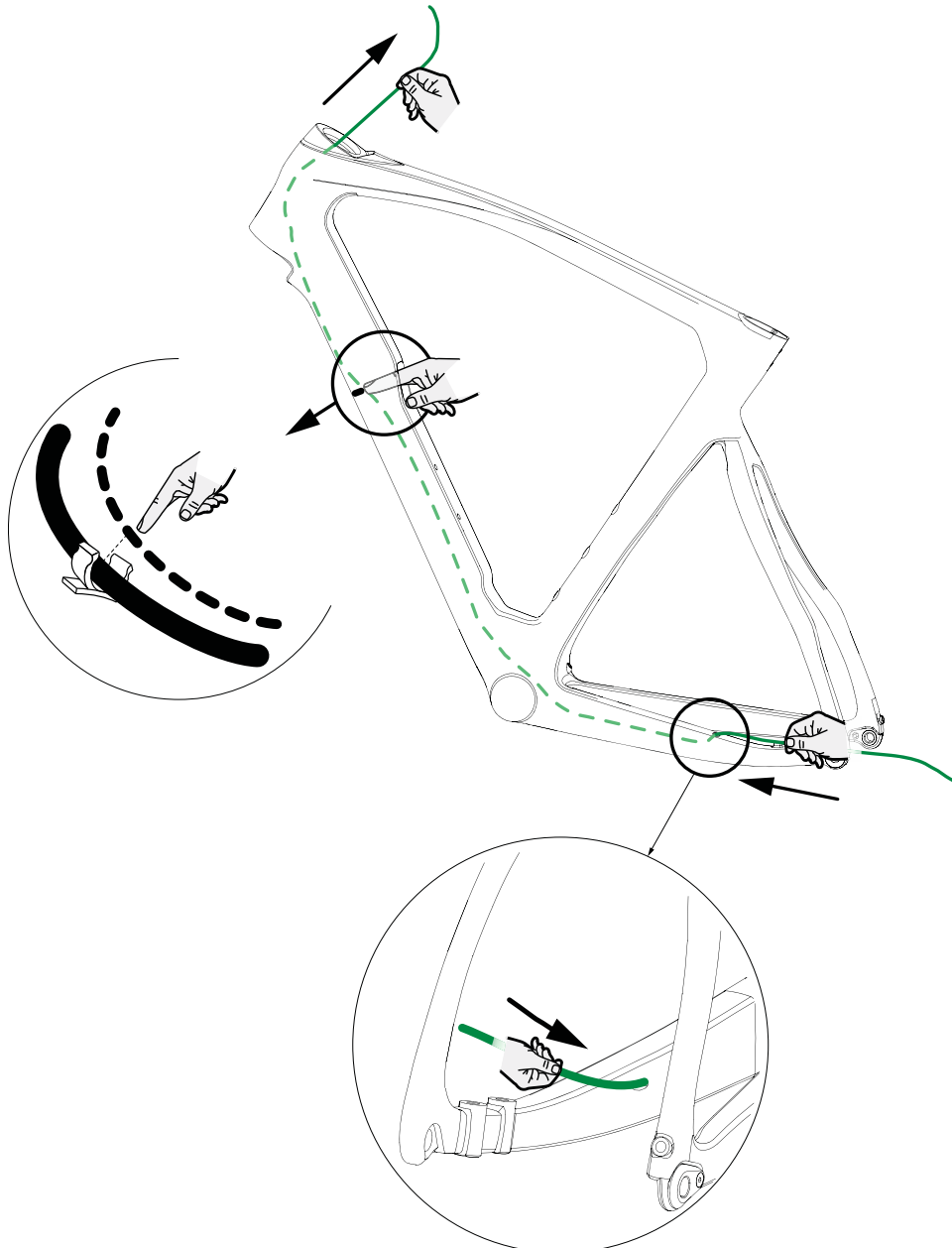

6. DISC BRAKE: INSTALLATION AND HOSE ROUTING

- 6.2** Install the rear brake caliper. Connect the rear brake to the left chainstay. Tighten the bolt until the brake is locked. It will be fully tightened only after alignment with disc rotor (refer to chapter "14. FINAL CHECKS" for more details).
ATTENTION! follow the brake OEM assembly instructions

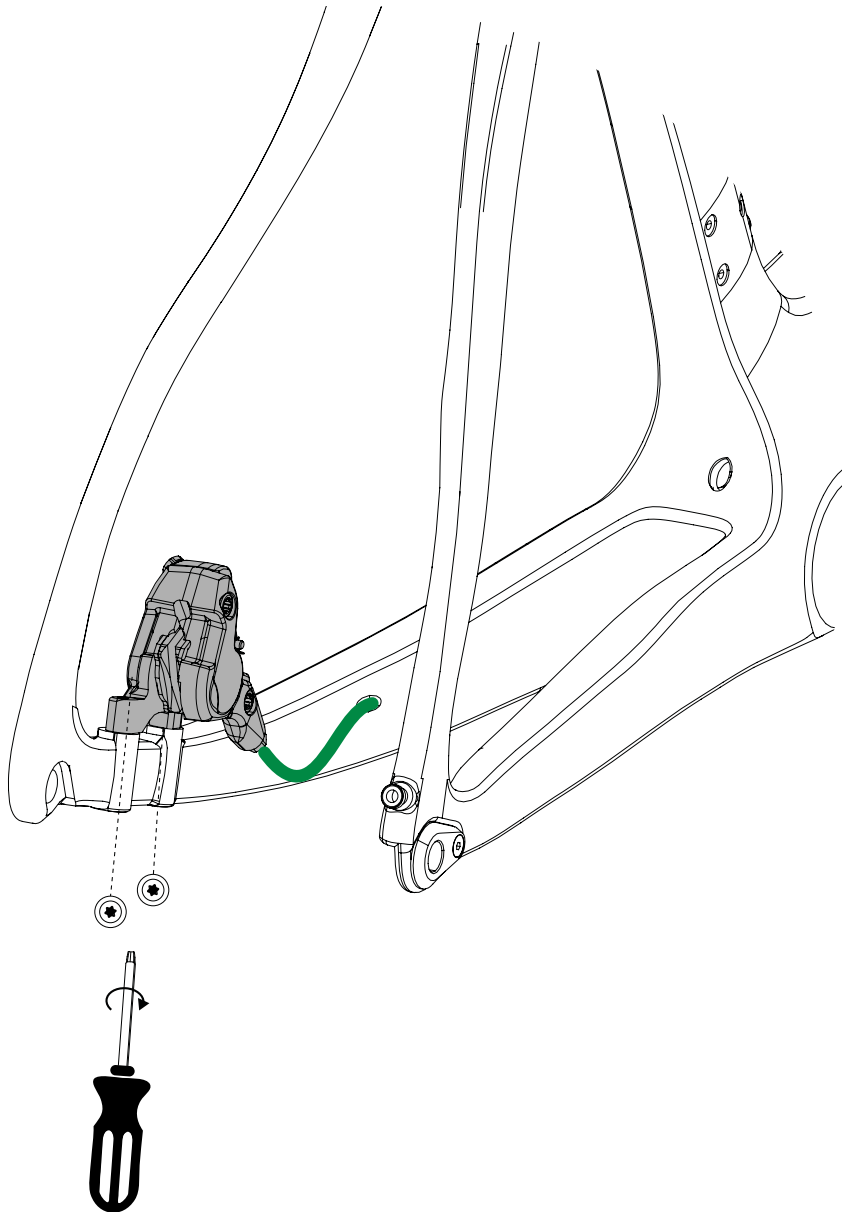

6. DISC BRAKE: INSTALLATION AND HOSE ROUTING

- 6.3** Route the FB hose through the fork entry hole (left fork arm) and up to the exit hole on the steerer tube. Refer to chapter "4. HOUSING AND HOSE LENGTH RECCOMANDATION" for the correct hose length.
- 6.4** Install the FB caliper to the fork. Tighten the bolt until the brake is locked. It will be fully tightened only after alignment with disc rotor (refer to chapter "14. FINAL CHECKS" for more details).
ATTENTION! follow the brake OEM assembly instructions.

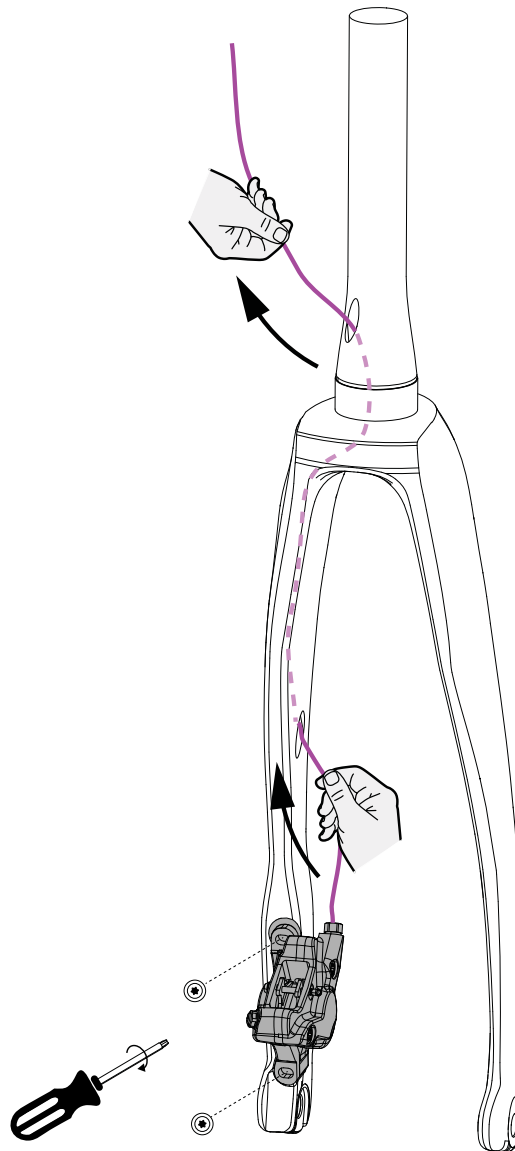

6. DISC BRAKE: INSTALLATION AND HOSE ROUTING

6.5 Headset top cap assembly:

- Install the lower headset bearing (bearing 1" ½ and crown race) into the proper frame seat.

ATTENTION! apply grease around the bearing frame seat.

- Push the steerer tube up into the head tube. Capture the FB hose inside the bearing and push up through the head tube. Use a proper support for the fork while installing.

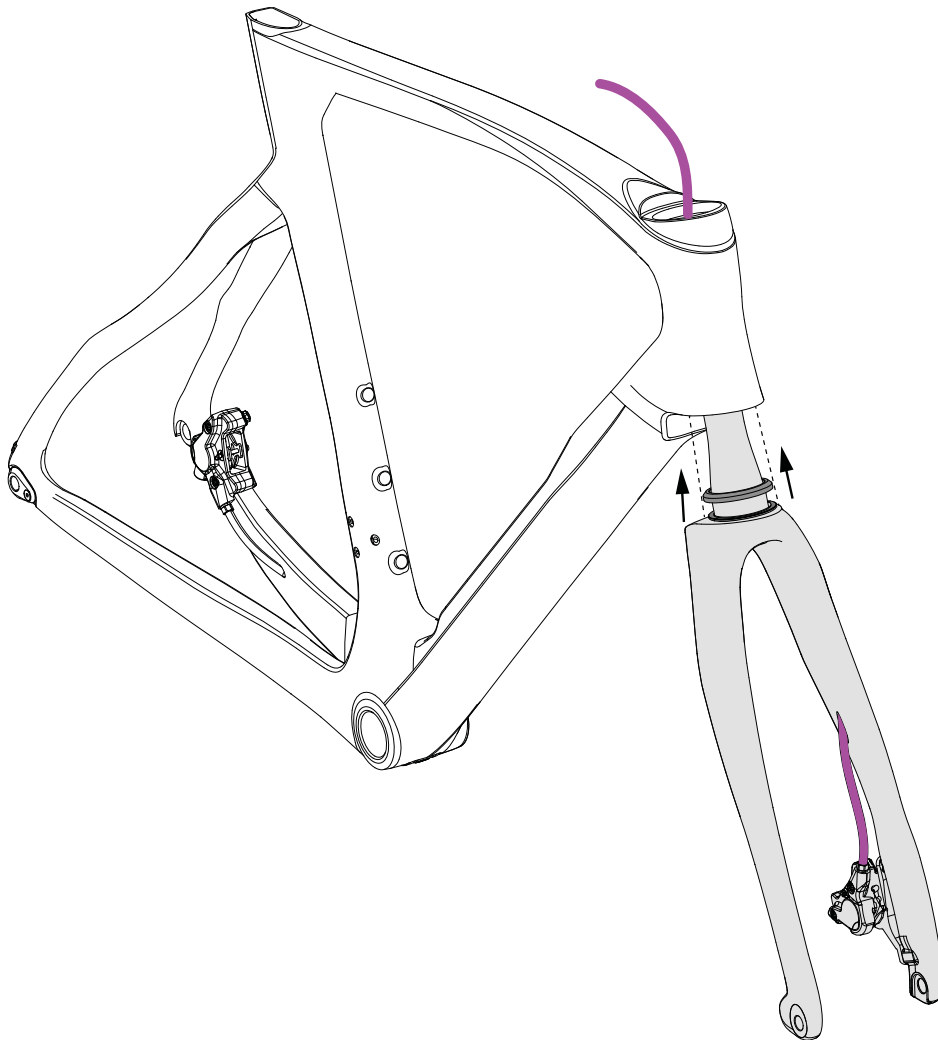

- Install the upper bearing in its frame seat. Make sure to capture the RB hose and the FB hose between bearing and steerer tube.

ATTENTION! apply grease around the bearing frame seat.

6. DISC BRAKE: INSTALLATION AND HOSE ROUTING

- Install the compression ring.

ATTENTION:

- the cut on compression ring must be on the backward side.
- the RB hose must be on the right notch in the compression ring.
- the FB hose must be on the left notch in the compression ring.

- Install the head set top cap. Make sure to keep the RB hose on the right notch in the head set top cap, and the FB hose on the left notch in the head set top cap.

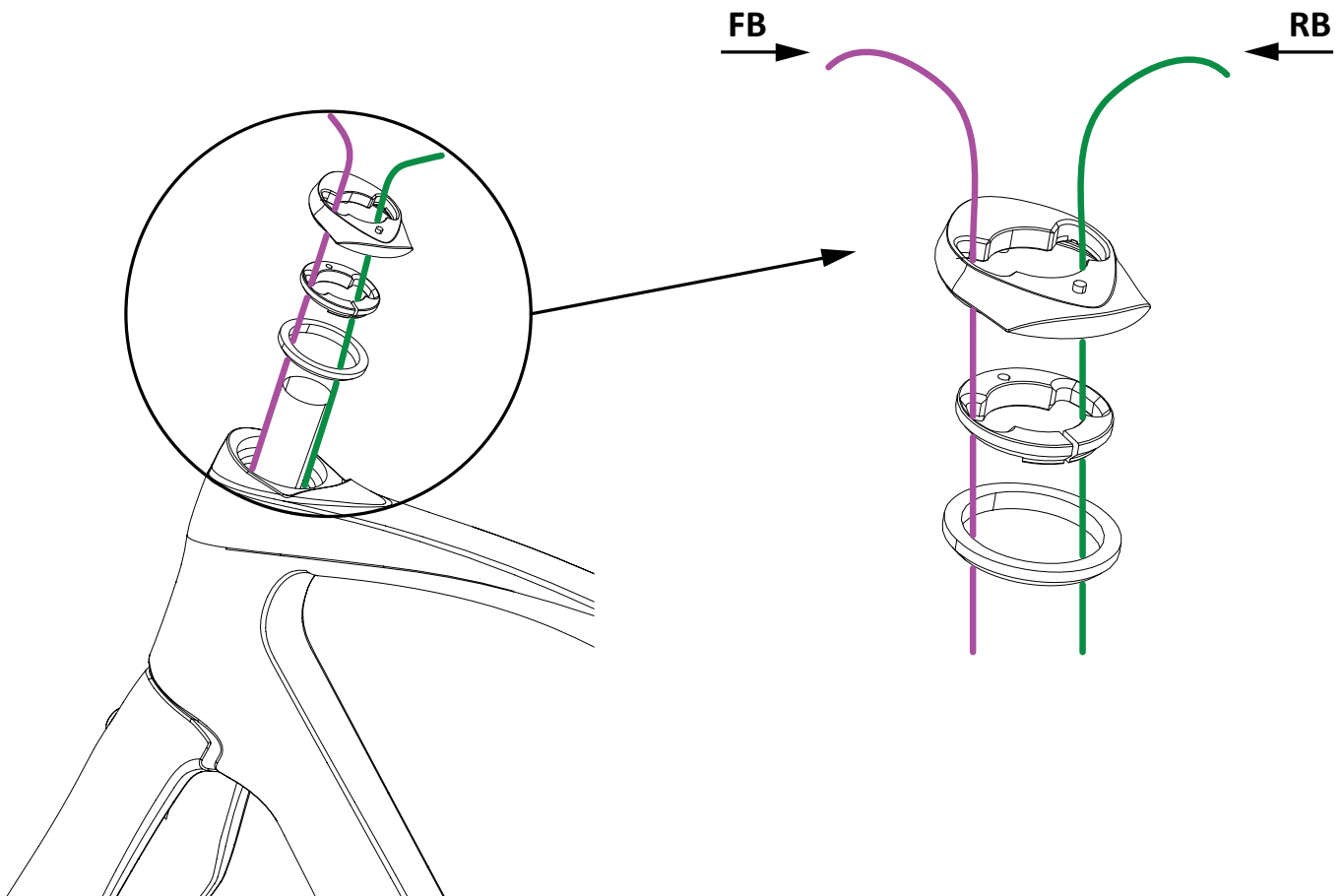

In case of Electronic groupset (Di2) go to chapter 7.

In case of Mechanical groupset go to chapter 8.

7. ELECTRONIC GROUPSET (DI2) INSTALLATION AND CABLE ROUTING

7.1 Electronic cable routing:

- Rear Derailleur (RD): pull 750 mm cable EW-SD50 from the right chainstay to the BB sleeve.
 - Front derailleur (FD): pull 350 mm cable EW-SD50 from the hole above FD to the BB sleeve.
 - Battery: pull 1000 mm cable EW-SD50 from the seat tube to the BB sleeve.
 - Di2 Interface: pull 600 mm cable EW-SD50 from the DT interface hole to the BB sleeve
- ATTENTION!** pass all four cables through the BB sleeve using the upper BB sleeve hole.

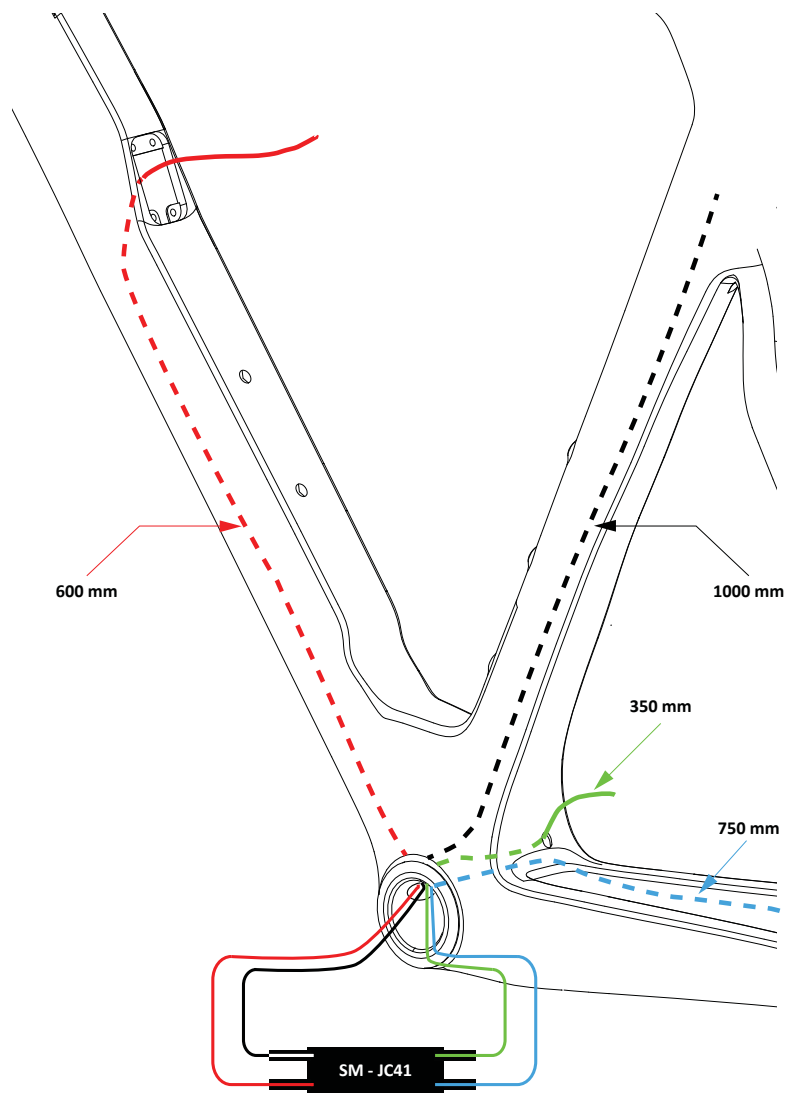

7. ELECTRONIC GROUPSET (DI2) INSTALLATION AND CABLE ROUTING

- Apply the heat-shrinking tubes to the four cables.
- Connect the four cables to the junction SM-JC41 and warm up the heat-shrinking tubes.
ATTENTION! max heating temperature 200°C, in order to not damage the electronic cables.
- Place the junction SM-JC41 into the frame through the BB sleeve hole.
ATTENTION! no cables must remain in the BB sleeve.

7.2 Rear Derailleur installation:

- Insert the RD wire grommet into the drop out exit hole.
- Install the rear derailleur to the RD hanger. Tighten following OEM torque spec.
- Attach the 750mm wire EW-SD50 to the RD.

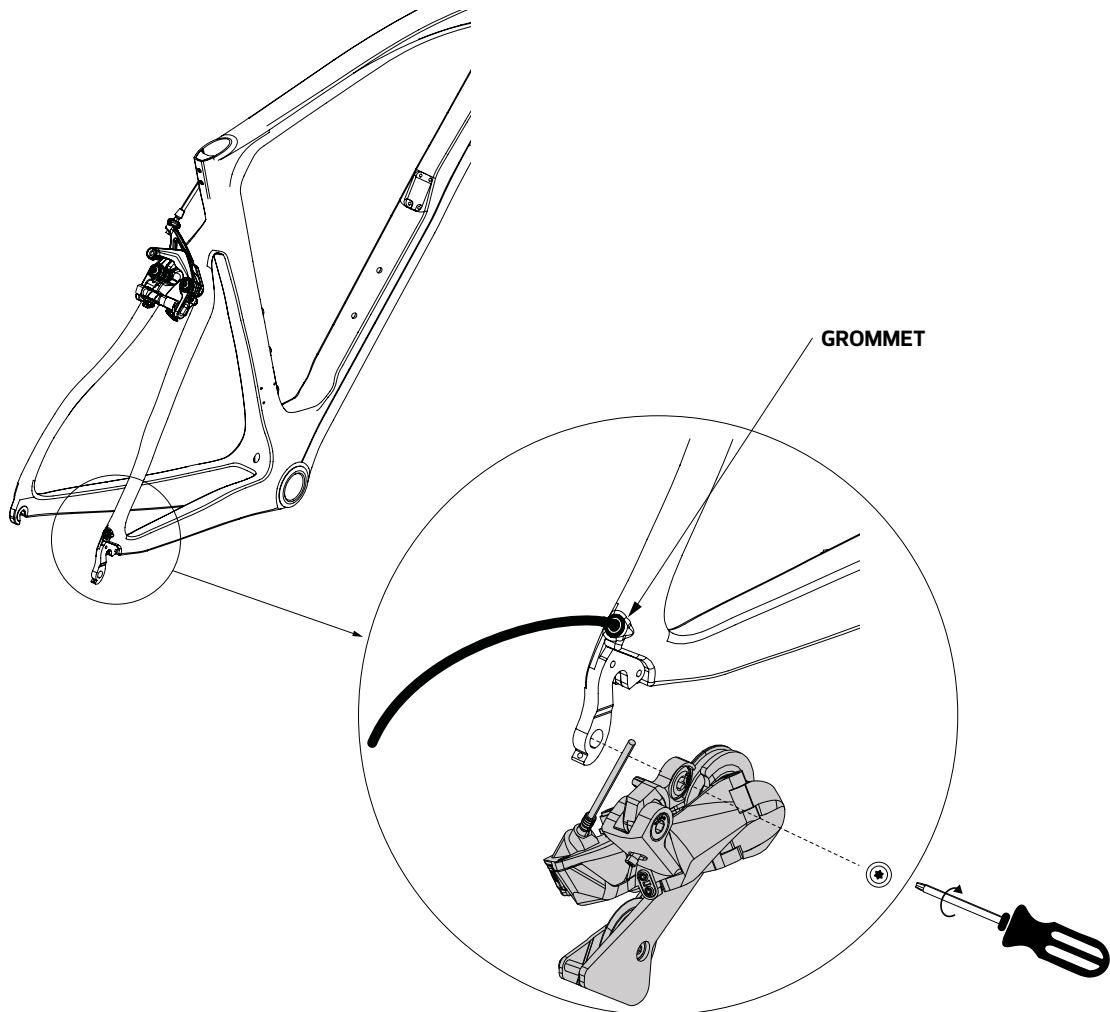

7. ELECTRONIC GROUPSET (DI2) INSTALLATION AND CABLE ROUTING

7.3 Front Derailleur installation:

- Insert the FD wire grommet into the seat tube exit hole
- Install the front derailleur to the FD hanger. Tighten the bolt until the FD is in place. It will be fully tightened, following OEM specs, only at the final tuning stage (refer to chapter "14. FINAL CHECKS" for more details).
- Attach the 350mm wire EW-SD50 to the FD

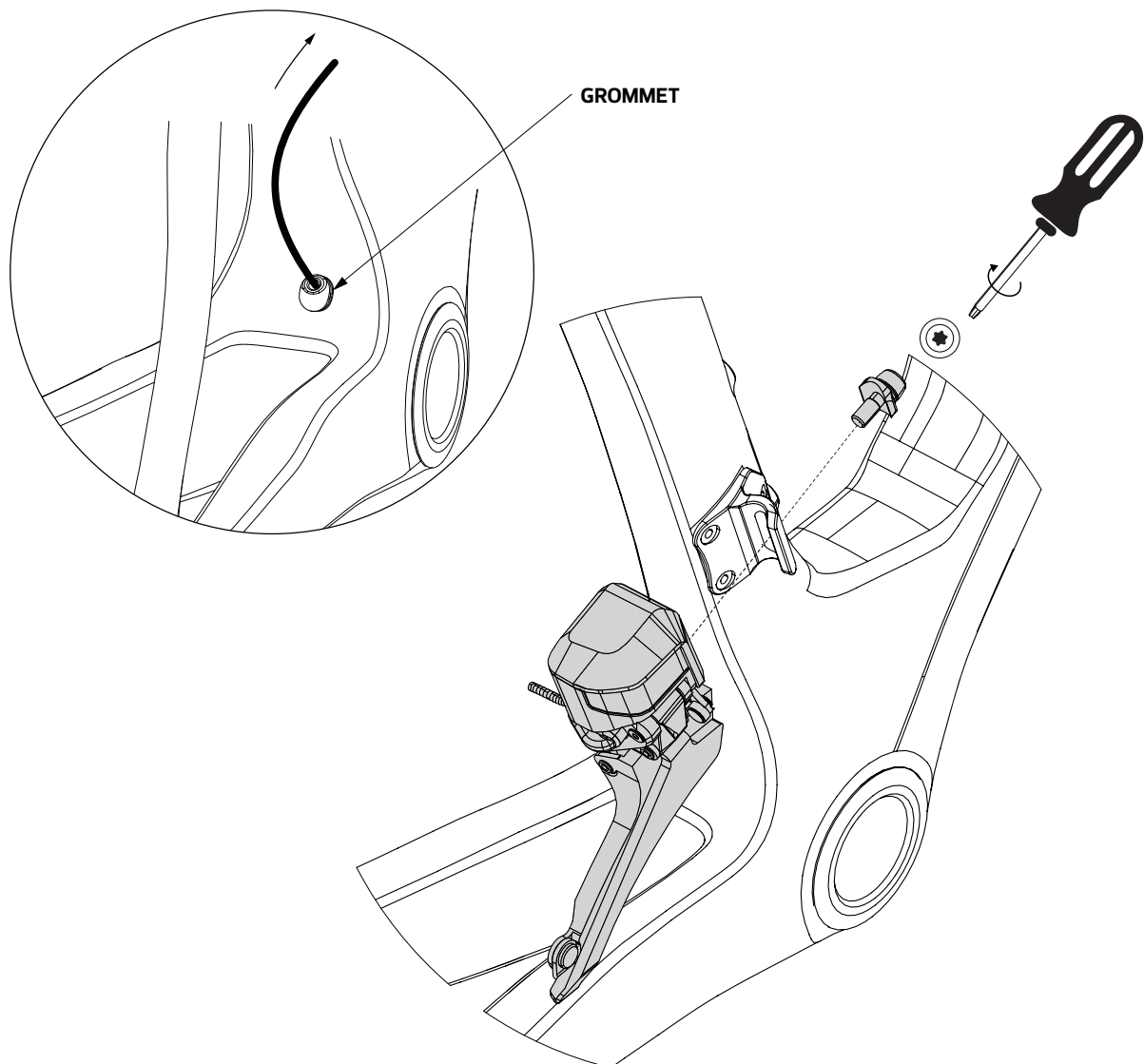

7. ELECTRONIC GROUPSET (DI2) INSTALLATION AND CABLE ROUTING

7.4 Battery installation (Shimano Di2):

- Install the battery into the seatpost using the battery hanger device. Make sure that the battery is completely insert into the seat post, just the battery connector should be outside.

ATTENTION! Battery hanger maximum torque: 2 Nm.

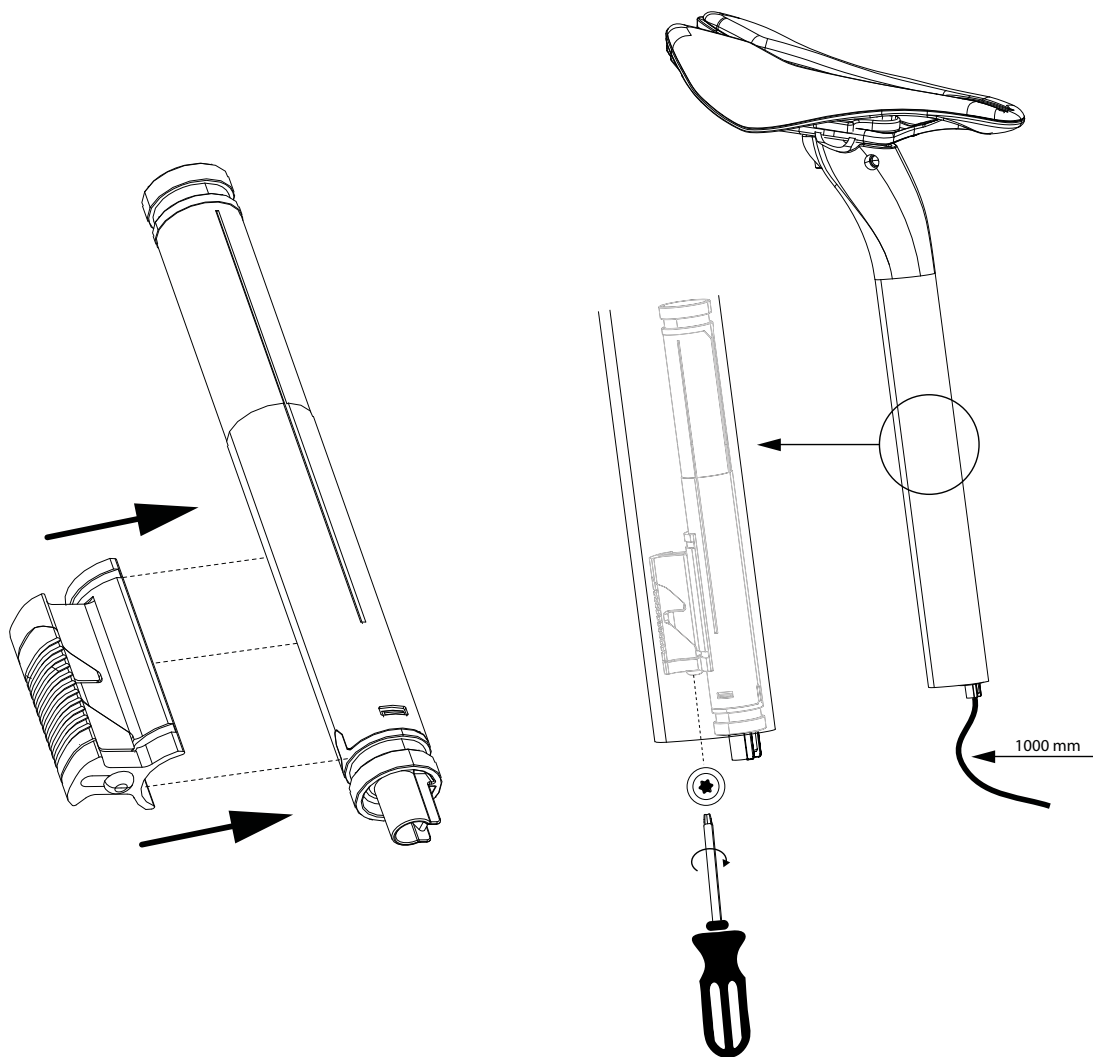

- Apply MOST Safe grip paste on the lower part of the seatpost to increase the friction with the seat post pocket.
- Connect the 1000mm wire EW-SD50 to the battery.
- Insert the seatpost into the seat tube.

7. ELECTRONIC GROUPSET (DI2) INSTALLATION AND CABLE ROUTING

- Insert the wedge between seatpost and frame.
- Tight the seat post hanger. Max torque: 4 Nm.

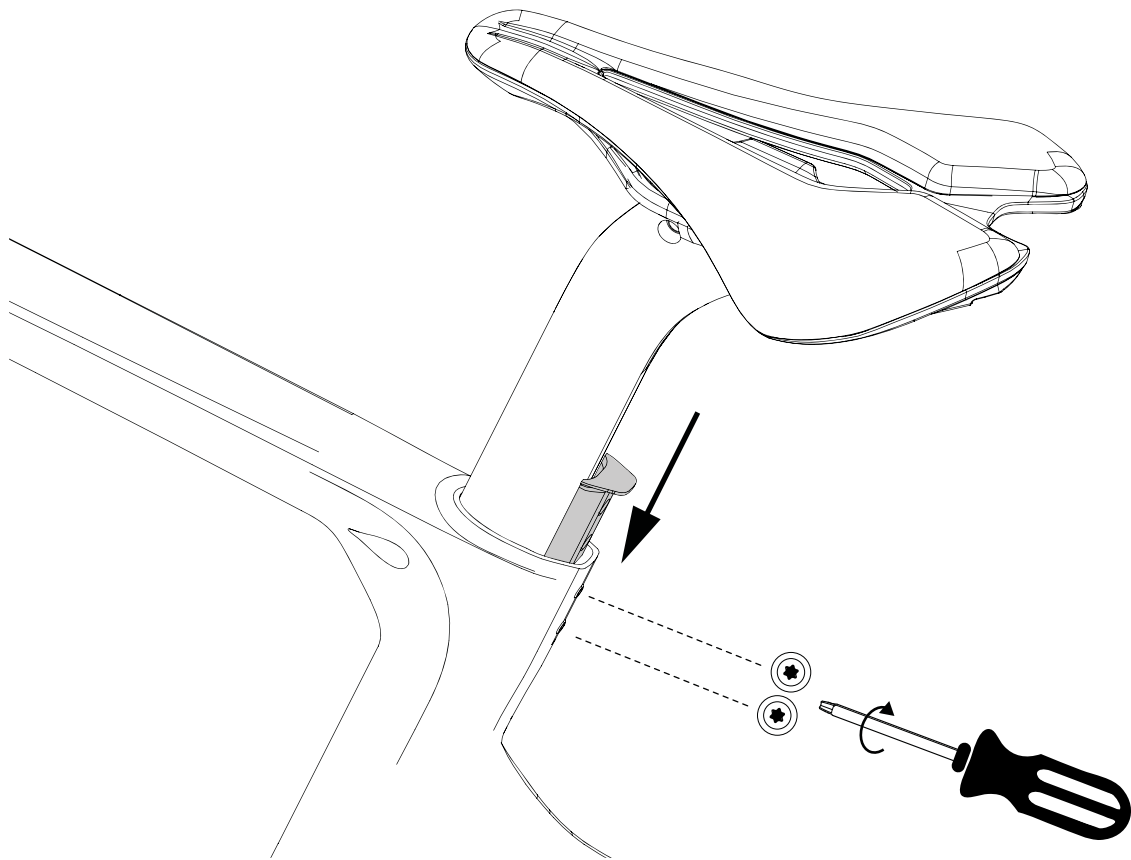

7.5 Install the BB, the crankset and the chain following the OEM instruction and recommended torques.

ATTENTION! BB compatibility: Italian thread 36 x 24T.

To carry on the electronic groupset (Di2) assembly go to chapter 9.

8. MECHANICAL GROUPSET INSTALLATION

8.1 Rear Derailleur installation:

- Install the rear derailleur to the RD hanger. Tighten following OEM torque spec.

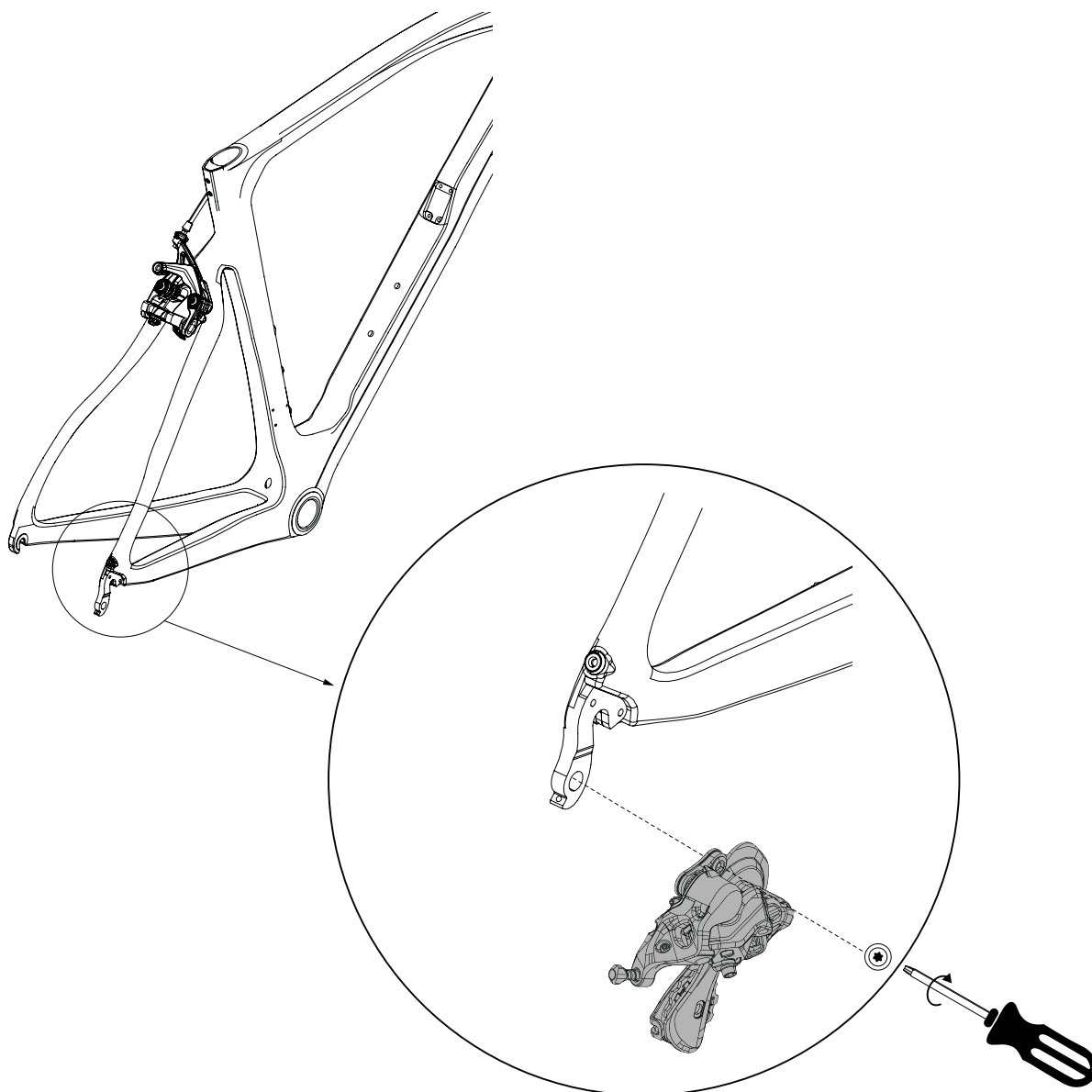

8. MECHANICAL GROUPSET INSTALLATION

8.2 Front Derailleur installation:

- Install the front derailleur to the FD hanger. Tighten the bolt until the FD is in place. It will be fully tightened, following OEM specs, only at the final tuning stage (refer to chapter "14. FINAL CHECKS" for more details).

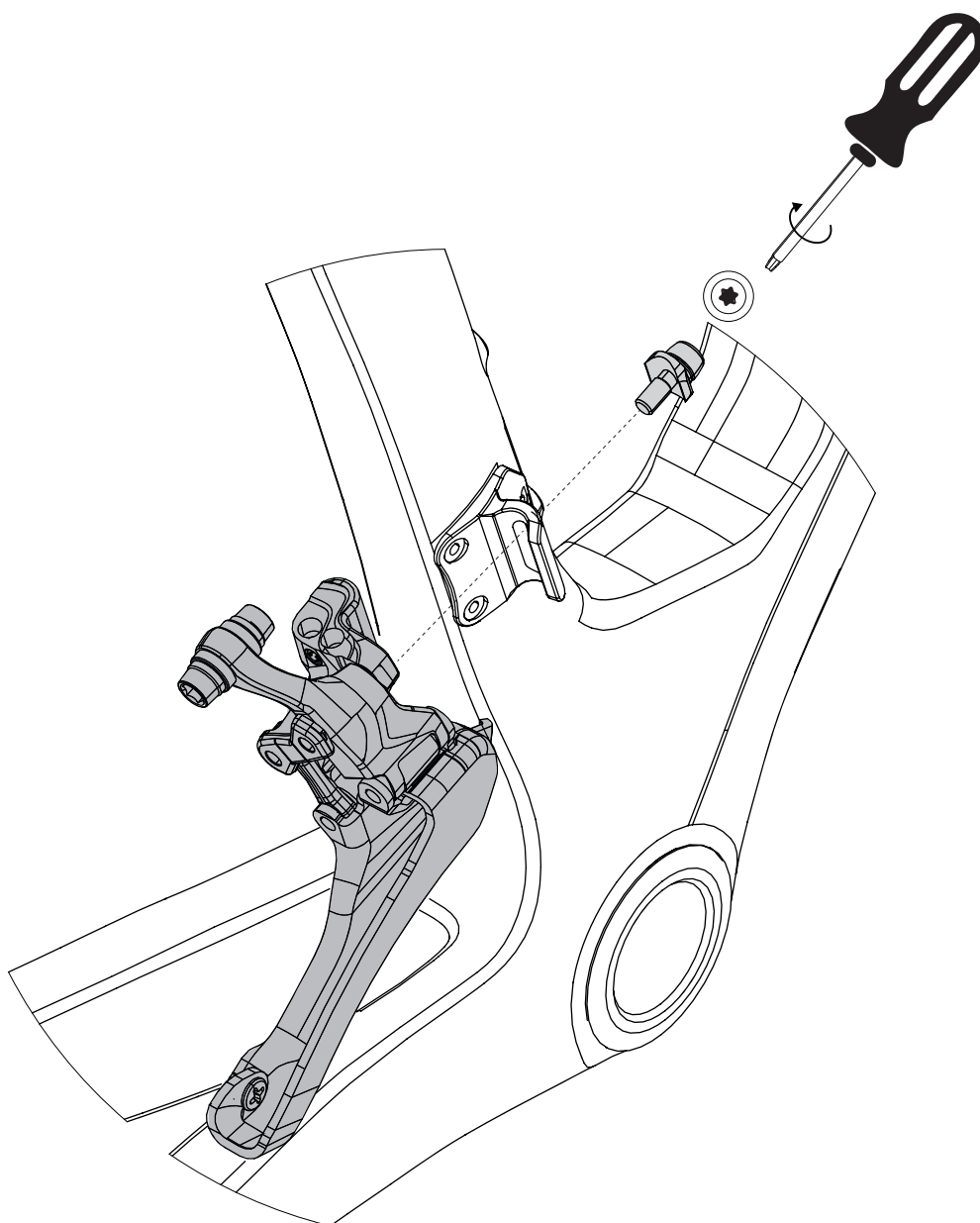

8. MECHANICAL GROUPSET INSTALLATION

8.3 Install the BB, the crankset and the chain following the OEM instruction and recommended torques.

ATTENTION! BB compatibility: Italian thread 36 x 24T.

8.4 Seatpost installation:

- Apply MOST Safe grip paste on the lower part of the seatpost to increase the friction with the seat post pocket.
- Insert the seatpost into the seat tube.
- Insert the wedge between seatpost and frame.
- Tight the seat post hanger. Max torque: 4 Nm.

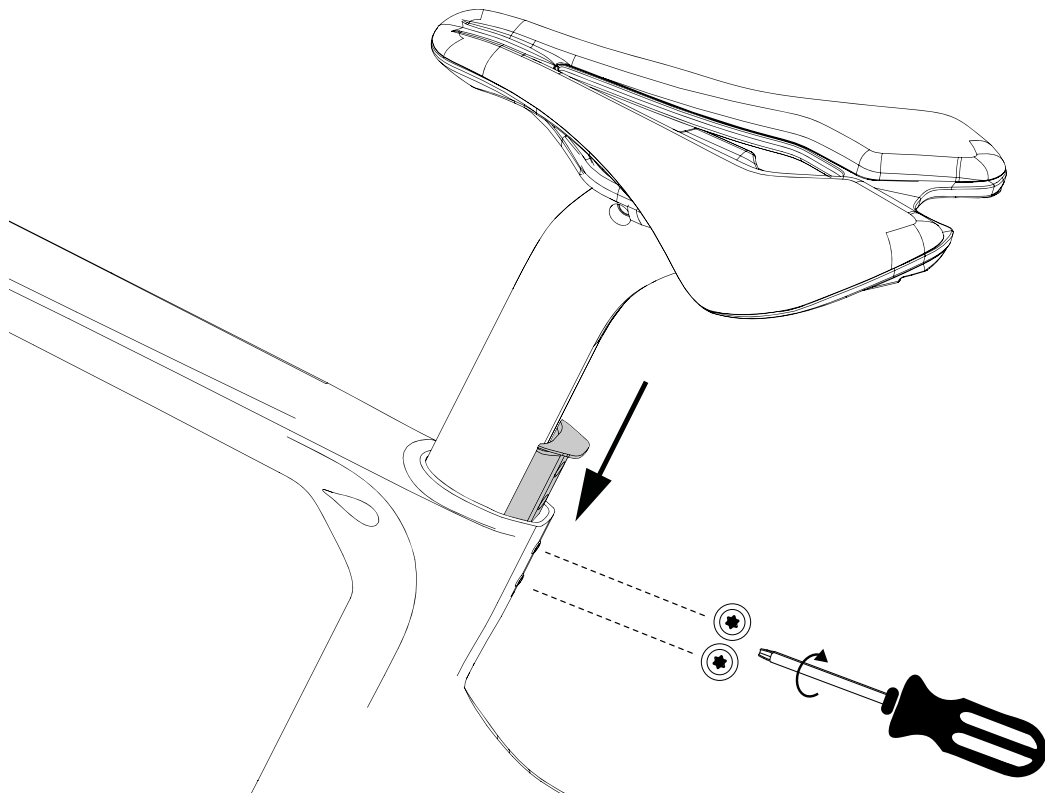

To carry on the mechanical groupset assembly go to chapter 10.

9. INTEGRATED HANDLEBAR (TALON ULTRA) ROUTING (ELECTRONIC DI2)

ATTENTION! If you do not install the integrated handlebar (Talon ULTRA), but instead a traditional stem and bar (or the Talon AERO); refer to this chapter in regard to the electronic cable routing inside the frame. Please refer to chapter “13. STEM AND BAR INSTALLATION AND ROUTING (FOUR CONFIGURATIONS)” for more details about traditional stem and bar assembling.

- 9.1 Install the shift levers on the Talon Ultra handlebar following the OEM specs.
- 9.2 Route the Y junction EW-JC130-SM from the middle of the handlebar to left and right exit hole. Connect Y junction connectors to the shift levers.

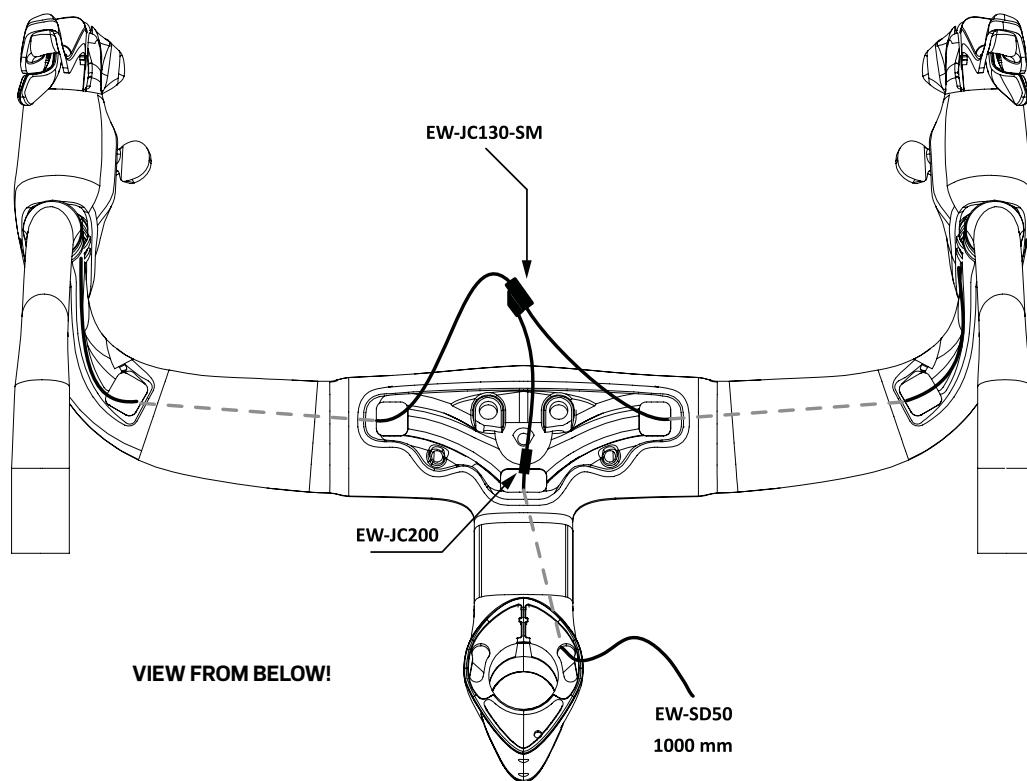

- 9.3 Connect the Y junction with the junction port EW-JC200 and with the 1000 mm cable EW-SD50.
 - Route the electronic cable through the stem until the left exit hole
 - Pull the electronic cable EW-SD50 out of the stem exit hole. The junction EW-JC200 must be completely hidden in the stem.

9. INTEGRATED HANDLEBAR (TALON ULTRA) ROUTING (ELECTRONIC DI2)

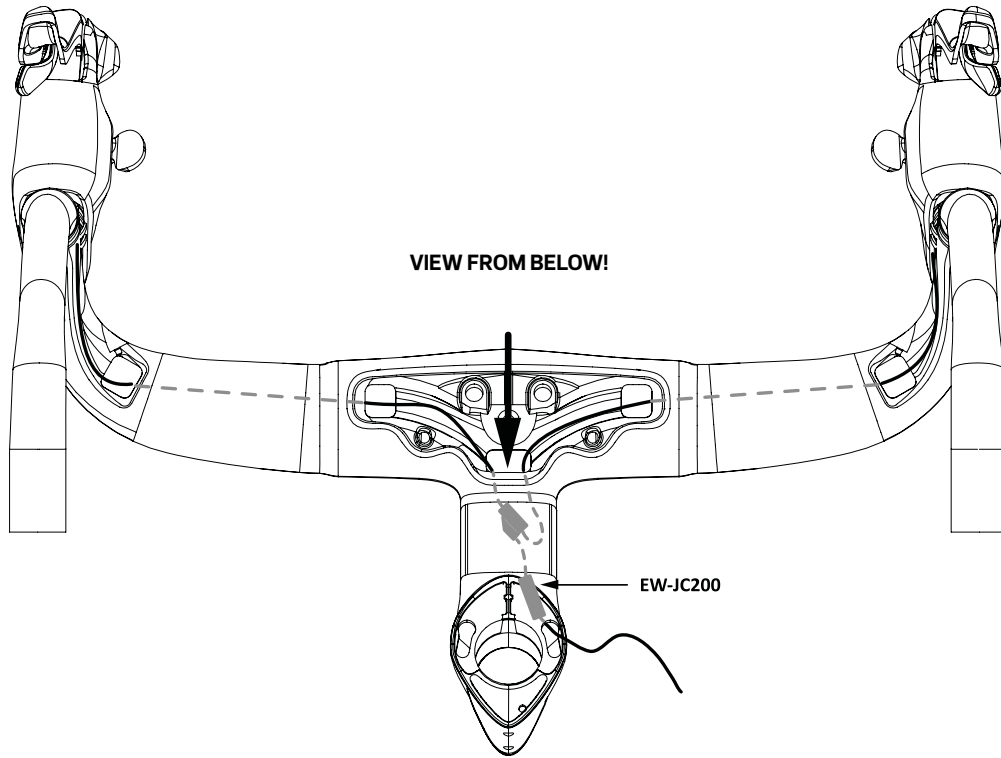

- 9.4** Install the handlebar on the steering tube. The lower support surface of the handlebar must be at $X+2$ cm away from the upper planar surface of the top cap. Where X is total height of the spacers you are going to install (e.g. if you install 3 cm of spacer, you must place the adapter at 5 cm away). This way you will have enough space to route the cables and assemble the spacers. Refer to chapter “12. HEADSET ADJUSTING” for more details about spacers.

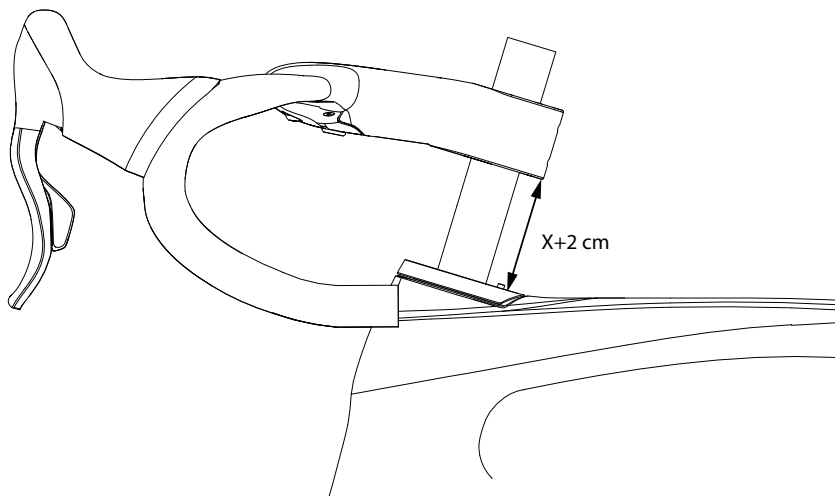

[where X is the total height of the spacers]

9. INTEGRATED HANDLEBAR (TALON ULTRA) ROUTING (ELECTRONIC DI2)

- 9.5** Route the electronic cable EW-SD50 connector through the headset top cap and through the compression ring. Make sure to route the cable through the left notch.
- 9.6** Route the 1000 mm cable EW-SD 50 through the head set top bearing and down through the DT until the DT opening for the junction.

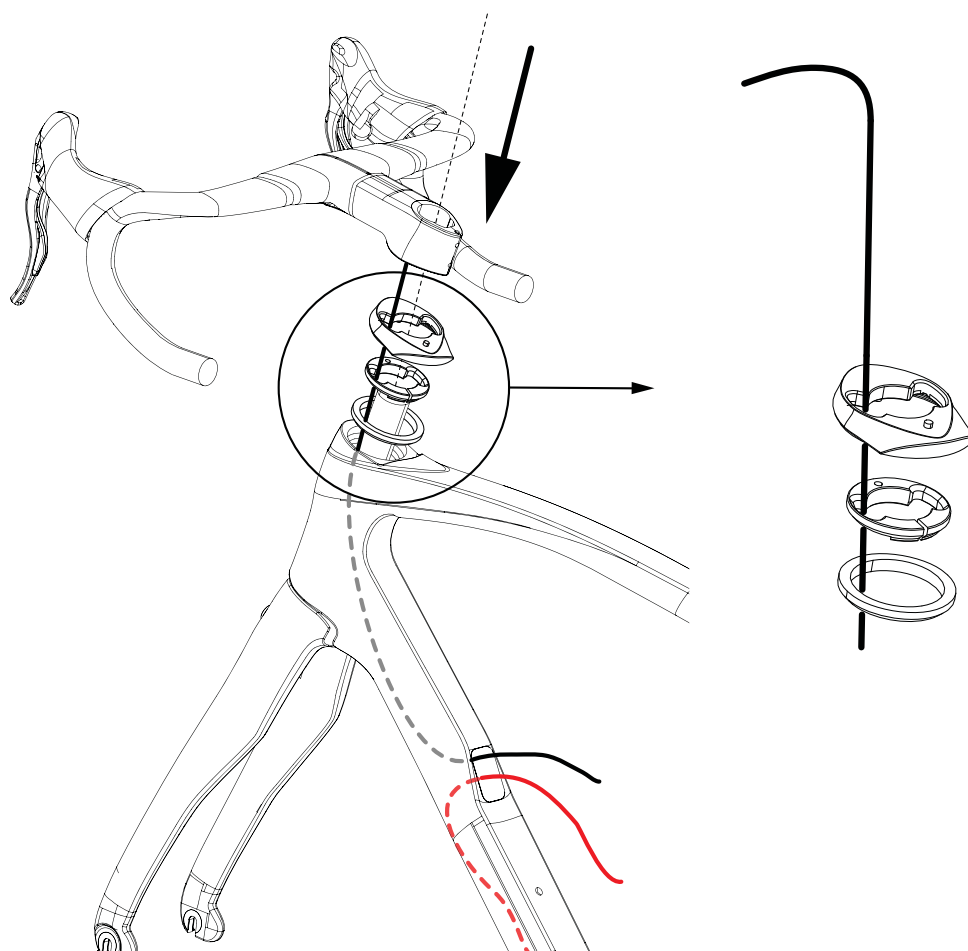

- 9.7** Insert the junction EW-RS910 into the plastic support interface.
- Connect the junction EW-RS910 to the cable EW-SD50 coming from handlebar and with the cable EW-SD50 coming from the BB.
 - Fix the junction EW-RS910 on the DT slot using the upper plastic cover and the M3 screws. Maximum allowed torque: 0.5 Nm.

9. INTEGRATED HANDLEBAR (TALON ULTRA) ROUTING (ELECTRONIC DI2)

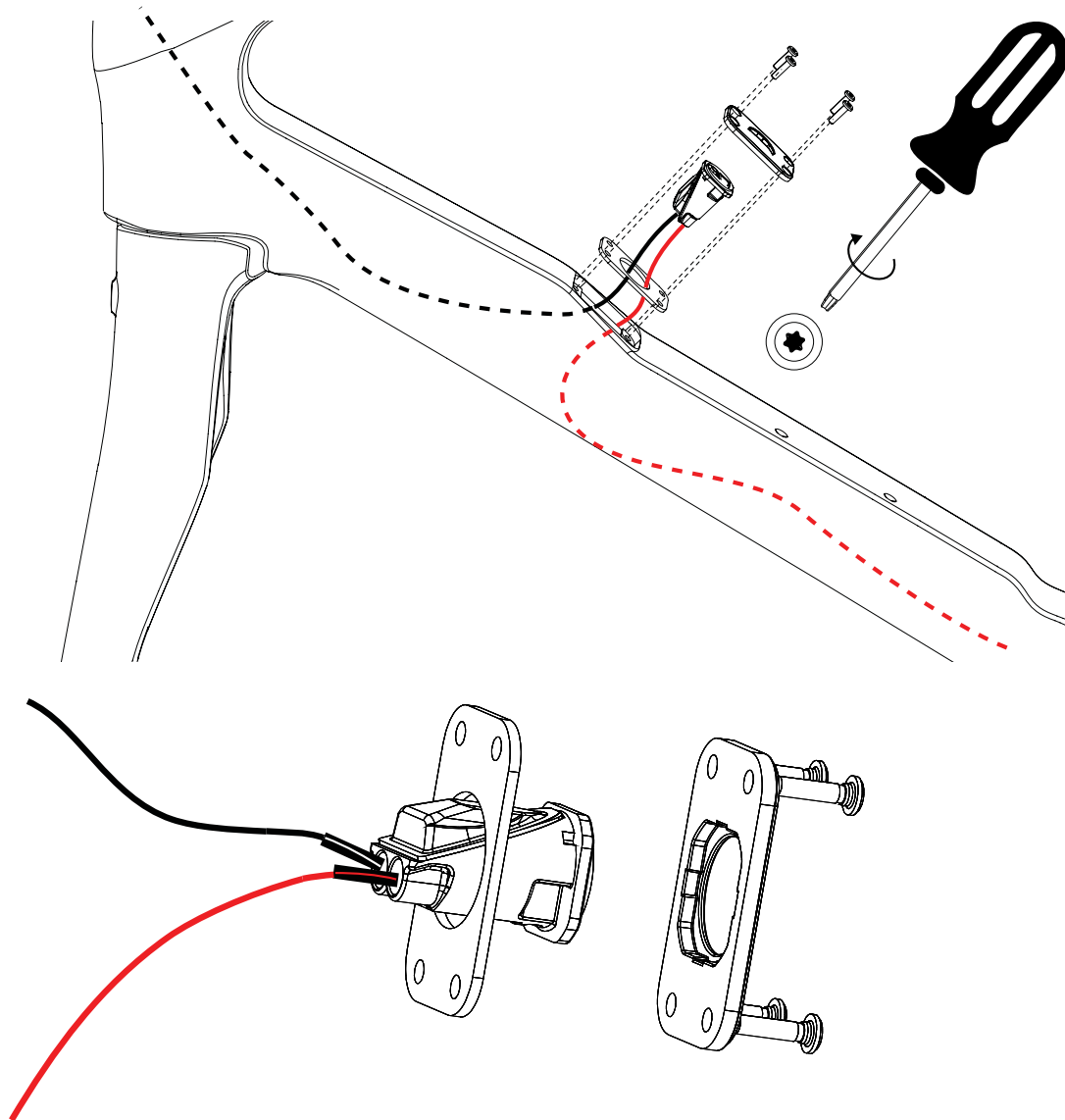

To carry on the electronic groupset (Di2) assembly go to chapter 11.

10. INTEGRATED HANDLEBAR (TALON ULTRA) ROUTING (MECHANICAL)

ATTENTION! If you don't install the integrated handlebar (Talon ULTRA), but instead the traditional stem and bar (or the Talon AERO); refer to this chapter in regard to the cable routing inside the frame. Please refer to chapter "13. STEM AND BAR INSTALLATION AND ROUTING (FOUR CONFIGURATIONS)" for more details about traditional stem and bar assembling.

10.1 Install the shift levers on the Talon Ultra handlebar following the OEM specs.

10.2 Handlebar cable routing:

- Route the RD housing from the left exit hole on the stem through the handlebar and out at the right exit hole at the lever.

- Route the FD housing from the right exit hole on the stem through the handlebar and out at the left exit hole at the lever.

Refer to chapter "4. HOUSING AND HOSE LENGTH RECCOMANDATION" for the correct housing lengths.

- Connect RD and FD housings to the levers following OEM specs and route RD/FD wires.

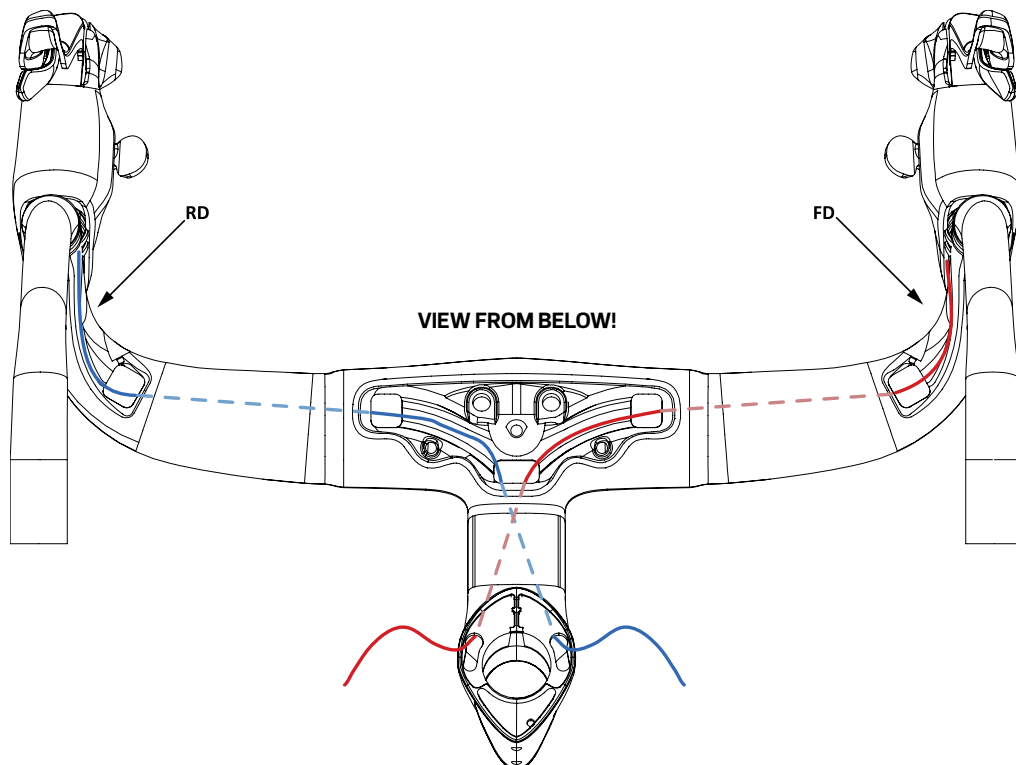

10. INTEGRATED HANDLEBAR (TALON ULTRA) ROUTING (MECHANICAL)

- 10.3** Install the handlebar on the steering tube. The lower support surface of the handlebar must be at $X+2$ cm away from the upper planar surface of the top cap. Where X is total height of the spacers you are going to install (e.g. if you install 3 cm of spacer, you must place the adapter at 5 cm away). This way you will have enough space to route the cables and assemble the spacers. Refer to chapter “12. HEADSET ADJUSTING” for more details about spacers.

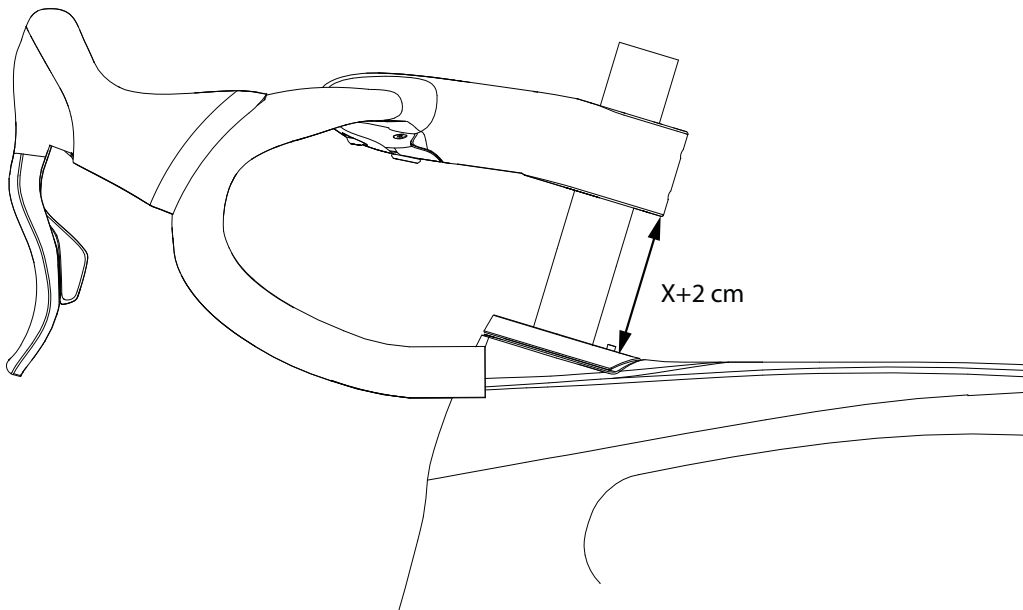

[where X is the total height of the spacers]

- 10.4** Frame cable routing:
- Route the RD housing through the headset top cap, the compression ring and the upper bearing using the left notch.
 - Route the FD housing through the headset top cap, the compression ring and the upper bearing using the right notch.
 - Route the RD and FD housings through the down tube until the DT opening.
- SUGGESTION: route the RD and FD housings with the wires inside. Once it has reached the DT opening, retract the wires for the adjuster installation.

10. INTEGRATED HANDLEBAR (TALON ULTRA) ROUTING (MECHANICAL)

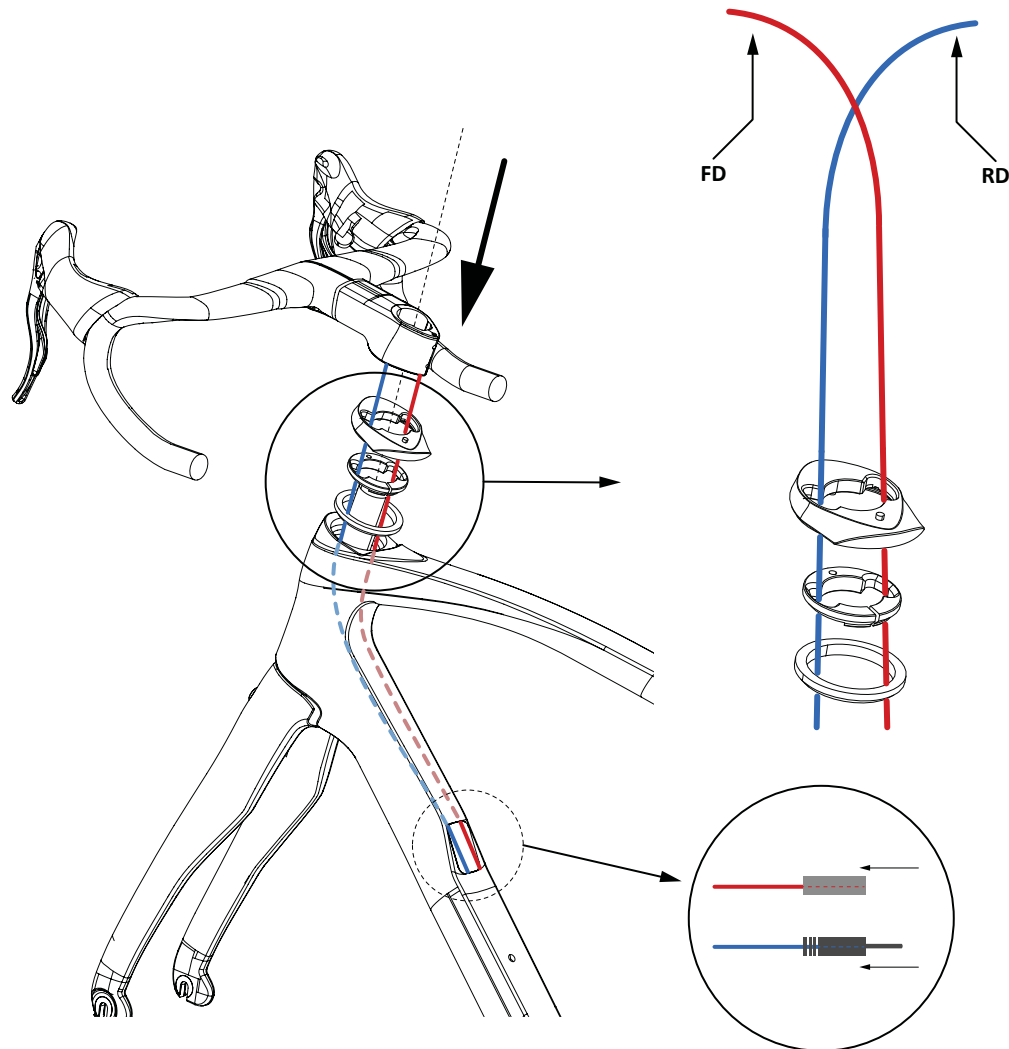

10.5 Adjuster assembly:

- Cut the RD and FD housings in correspondence of the lower short edge of the DT opening. Make sure the housings are properly positioned in the frame, to prevent them from being twisted together and/or scratched.
- Install the metal end cap on the FD housing and the plastic one on the RD housing.
- Insert the FD housing (with metal end cap) in the front left hole of the adjuster case ①. The lower wedge ③ must be held in place, inside the case ①, by the Teflon pipe ② coming out of the case's left back hole. Pay attention to insert the metal end cap also in the lower wedge ③ seat. In this way the FD housing, the case ①, the wedge ③ and the Teflon pipe ② are a single body.
- Insert the RD housing on adjuster using the case ① right hole.

10. INTEGRATED HANDLEBAR (TALON ULTRA) ROUTING (MECHANICAL)

- Place the adjuster case (1), with the FD and RD housings installed, on the DT. Make sure that FD and RD housings are well positioned.
- Preinstall the upper wedge (4), the cap (5) and the adjusting screw (6), taking care that the screw (6) is completely screwed to the wedge (4) (the cap (5) remains between the other two components). Pay attention to the proper orientation of the wedge (4).
- Mount the preinstalled components of the previous point ((4), (5), (6)) on the case previously placed.
- Fix all the mechanism using the adjuster cover (7) and the four M3 screws. Maximum allowed torque: 0.5 Nm.

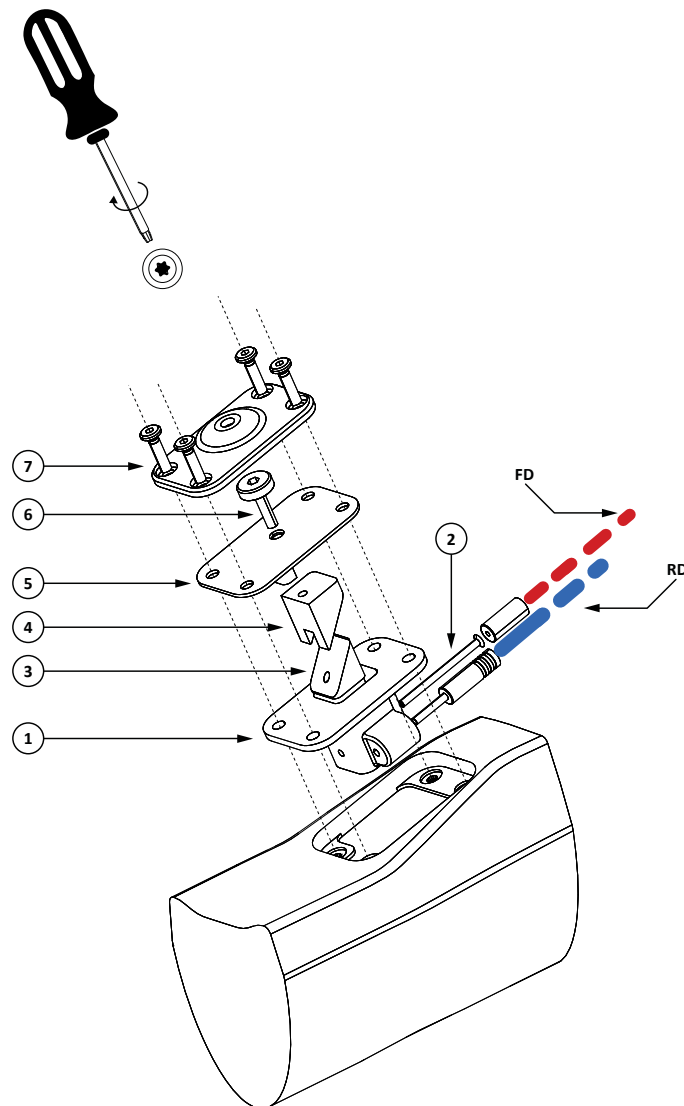

10. INTEGRATED HANDLEBAR (TALON ULTRA) ROUTING (MECHANICAL)

- 10.6** Route the FD and RD wires from the levers until the BB hole below the bottom bracket. The wire will route automatically through the adjuster.
- Route the FD wire through the FD exit hole on the rear part of the seat tube, using Teflon pipe.
 - Route the RD wire through the right chainstay until the exit hole just above the dropout.
 - Install the plastic BB guide and fix it with M4 screw. Tightening torque: 2 Nm.
 - Connect FD wire to the FD following OEM instructions. Don't forget to install the proper grommet into the seat tube exit hole.
 - Connect RD wire to the RD following OEM instructions. Don't forget to install the proper aluminum bushing and the Teflon pipe inside, into the right chainstay exit hole.
- ATTENTION! The final tuning of the drivetrain (both FD and RD) will be done only at final stage (see chapter "14. FINAL CHECKS").**

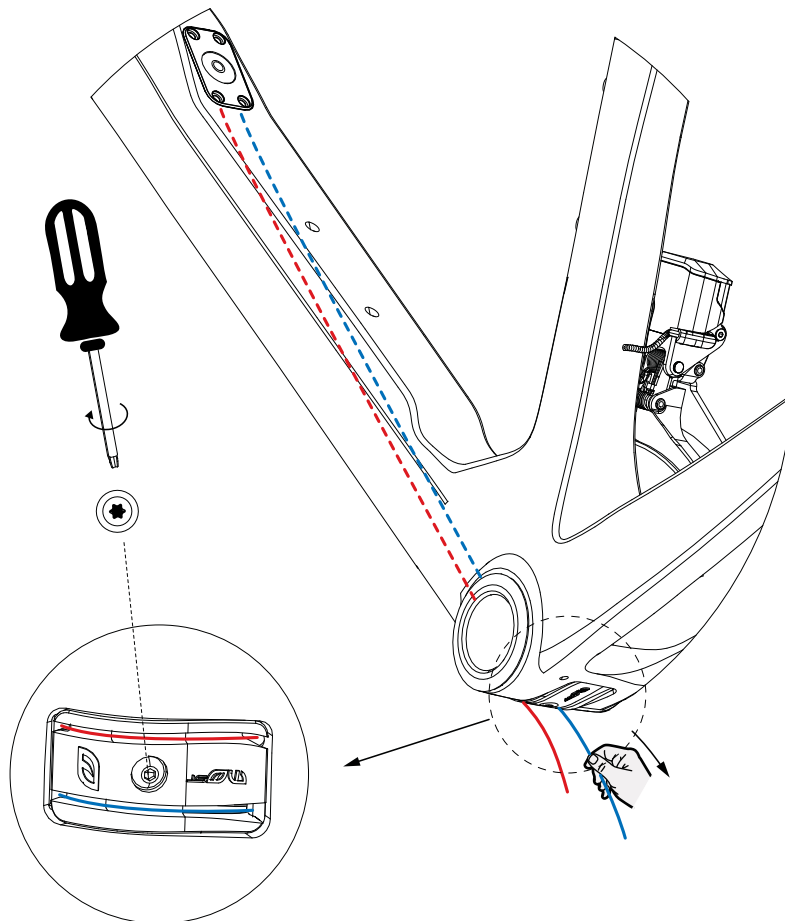

10. INTEGRATED HANDLEBAR (TALON ULTRA) ROUTING (MECHANICAL)

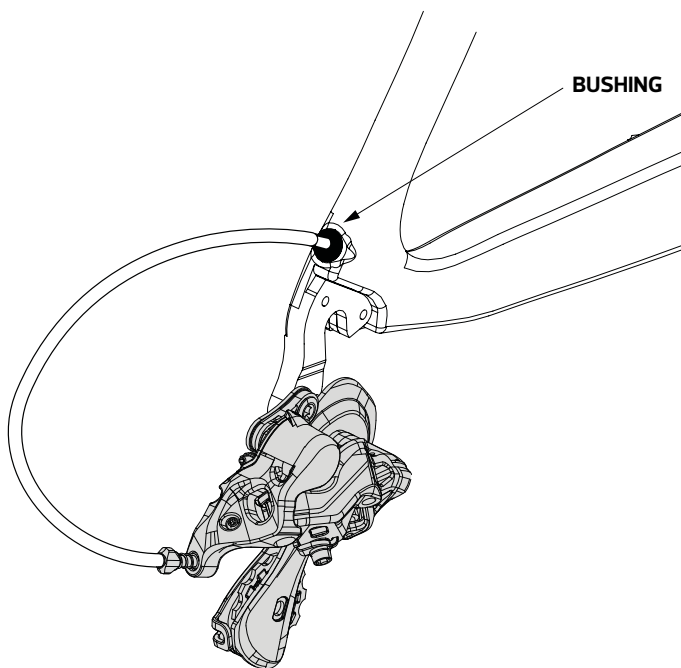
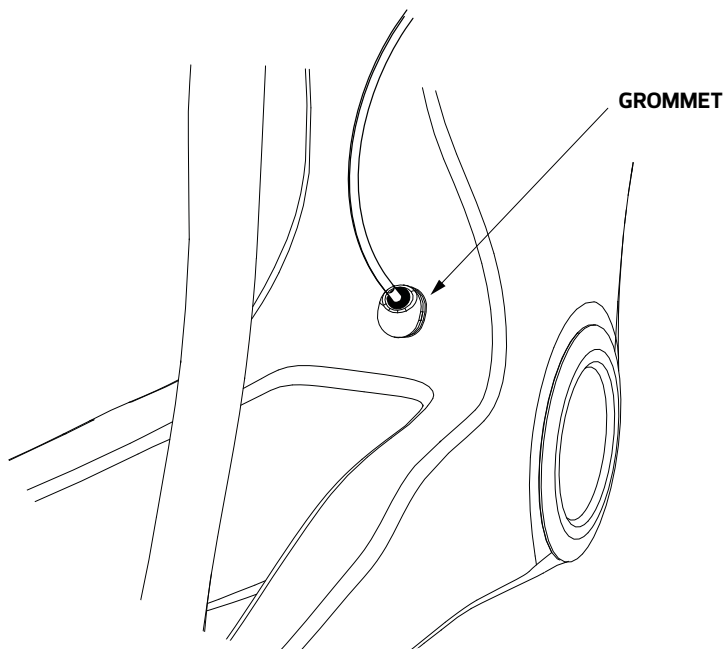

11. BRAKE CABLE INSTALLATION (INTEGRATED HANDLEBAR)

ATTENTION! If you don't install the integrated handlebar (Talon ULTRA), but instead a traditional stem and bar (or the Talon AERO); refer to this chapter in regard to general instructions about brake assembly. Then refer to chapter "13. STEM AND BAR INSTALLATION AND ROUTING (FOUR CONFIGURATIONS)" for more details about stem and bar assembling.

Possible configurations:

PARAGRAPH	BRAKES TYPE	DRIVETRAIN TYPE
11.1	Rim	Electronic (Di2)
11.2	Rim	Mechanical
11.3	Disc	Electronic (Di2)
11.4	Disc	Mechanical

11. BRAKE CABLE INSTALLATION (INTEGRATED HANDLEBAR)

11.1 RIM & ELECTRONIC (Di2)

Steps that must be followed before:

5. RIM BRAKE: INSTALLATION AND HOUSING ROUTING

7. ELECTRONIC GROUPSET (Di2) INSTALLATION AND CABLE ROUTING

9. INTEGRATED HANDLEBAR (Talon ULTRA) ROUTING (Electronic Di2)

11.1.1 Route the RB housing (that comes out from the head tube) into the handlebar, the Talon ULTRA. Pass the housing from the right-hand side stem hole until the right exit hole near the lever.

11.1.2 Connect the RB housing to the lever following OEM specs.

11.1.3 Connect the RB housing at the rear brake caliper and place the proper rubber plug to protect the frame.

ATTENTION! Leave enough housing to allow the correct operation to the rear brake caliper.

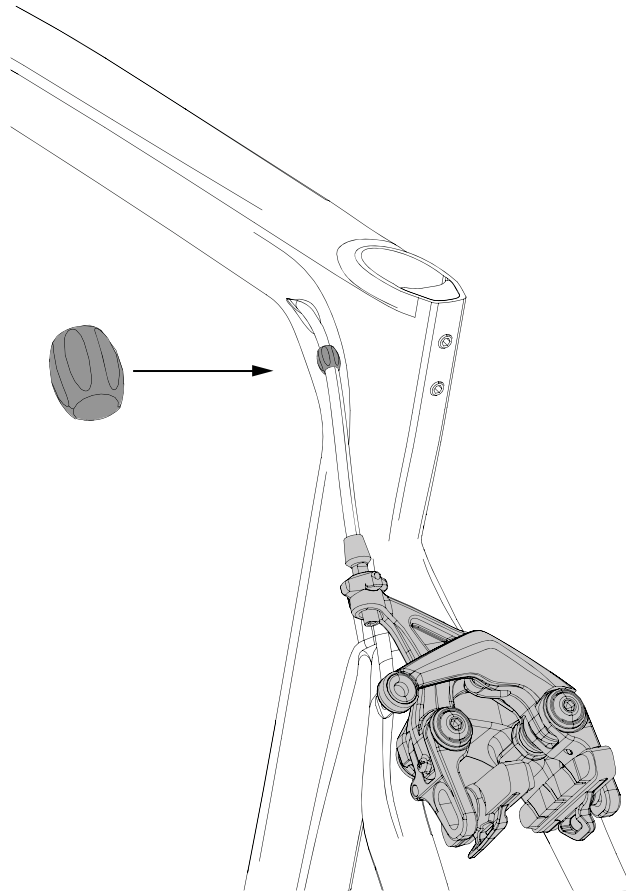

11. BRAKE CABLE INSTALLATION (INTEGRATED HANDLEBAR)

- 11.1.4** Route the FB housing into the handlebar Talon Ultra. Pass the housing from the left-hand side bar hole until the left exit hole near the lever.
- 11.1.5** Connect FB housing to the lever following OEM specs.
- 11.1.6** The handlebar cable routing looks like this:

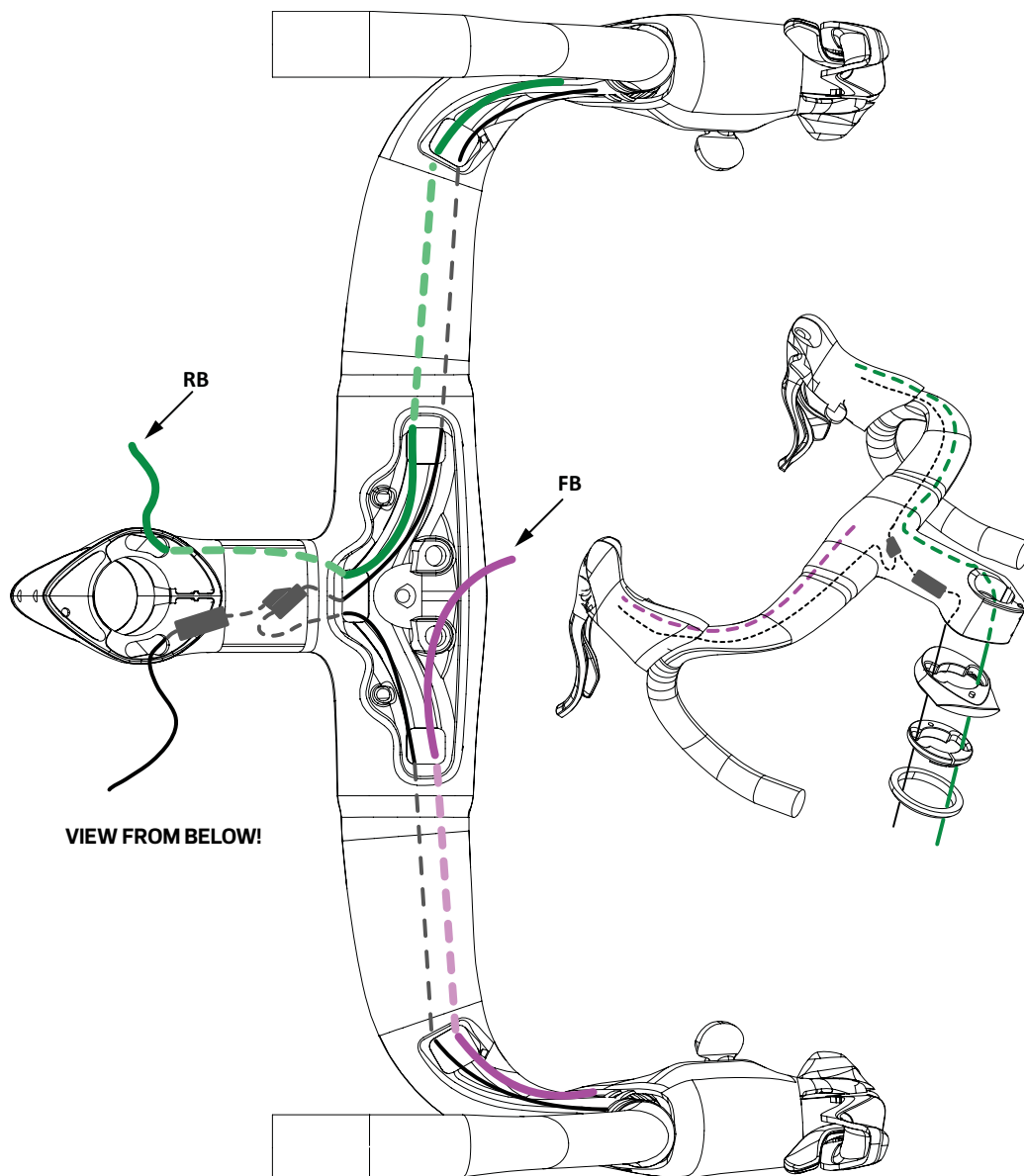

11. BRAKE CABLE INSTALLATION (INTEGRATED HANDLEBAR)

- 11.1.7 Install the holed rubber plug into the Talon ULTRA plastic cover.
- 11.1.8 Run the FB housing and cable through the plastic cover and the holed rubber plug.
- 11.1.9 Fix the cover to the handlebar with four screws. For the correct tightening torques, refer to the chart of the chapter "3. TOOLS AND TORQUE SPECS".

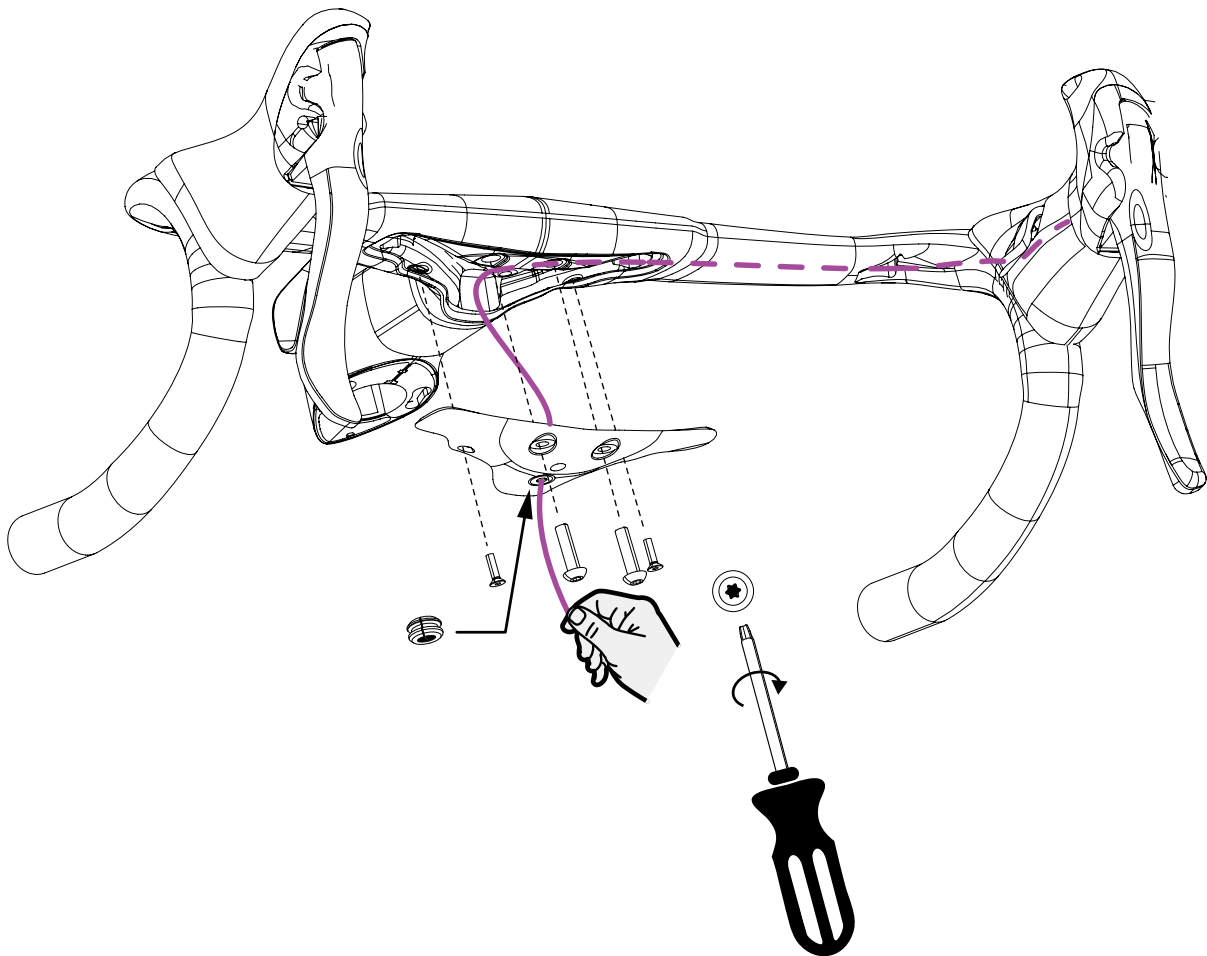

- 11.1.10 Connect the FB housing to the front brake caliper following OEM instructions.
- 11.1.11 Run the RB and FB cables from shifter levers through the housings and connect them to the brake calipers following OEM specs.

ATTENTION! The final tuning of the brakes (both FB and RB) will be done only at final stage (see chapter "14. FINAL CHECKS").

11. BRAKE CABLE INSTALLATION (INTEGRATED HANDLEBAR)

11.2 RIM & MECHANICAL

Steps that must be followed before:

5. RIM BRAKE: INSTALLATION AND HOUSING ROUTING

8. MECHANICAL GROUPSET INSTALLATION

10. INTEGRATED HANDLEBAR (Talon ULTRA) ROUTING (Mechanical)

Follow steps 11.1.1, 11.1.2, 11.1.3, 11.1.4, 11.1.5 as before.

11.2.1 The handlebar cable routing looks like this:

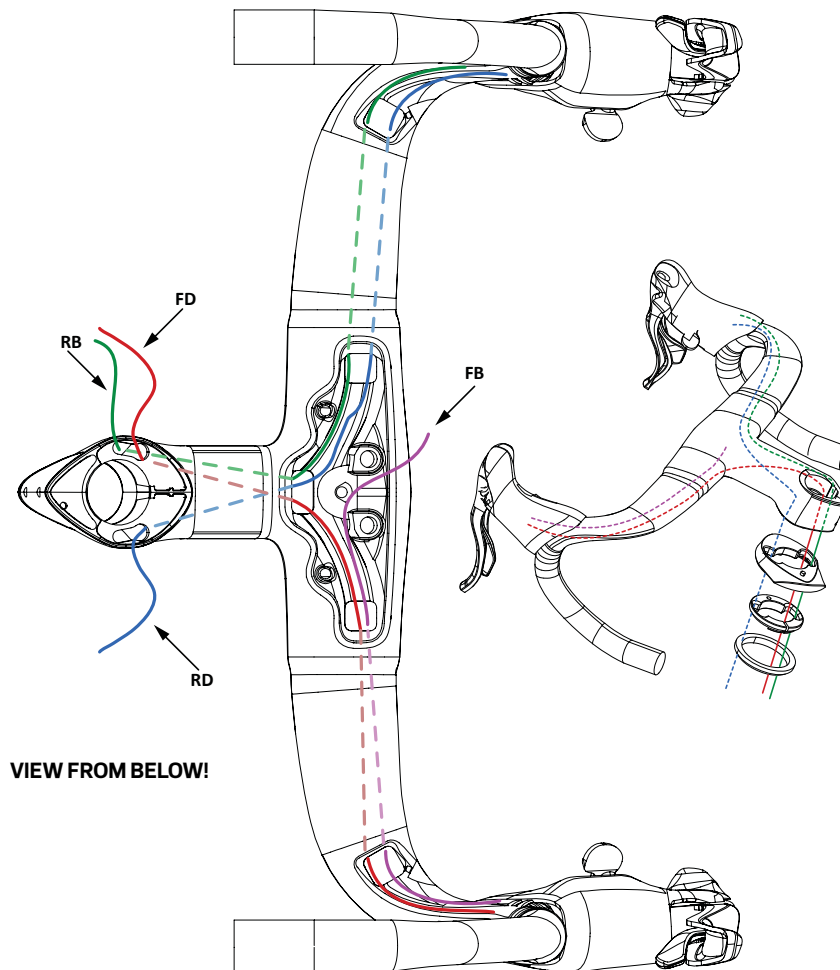

ATTENTION! In the stem exit hole on the right-hand side the FD housing must be in front of the RB housing.

Follow steps 11.1.7, 11.1.8, 11.1.9, 11.1.10, 11.1.11 as before.

11. BRAKE CABLE INSTALLATION (INTEGRATED HANDLEBAR)

11.3 DISC & ELECTRONIC (Di2)

Steps that must be followed before:

6. DISC BRAKE: INSTALLATION AND HOSE ROUTING

7. ELECTRONIC GROUPSET (Di2) INSTALLATION AND CABLE ROUTING

9. INTEGRATED HANDLEBAR (Talon ULTRA) ROUTING (Electronic Di2)

11.3.1 Route the RB hose (that comes out from the head tube) into the handlebar, the Talon ULTRA. Pass the housing from the right-hand side stem hole until the right exit hole near the lever.

11.3.2 Route the FB hose (that comes out from the head tube) into the handlebar, the Talon ULTRA. Pass the housing from the left-hand side stem hole until the left exit hole near the lever.

[continue on the next page]

11.3.3 The handlebar cable routing looks like this:

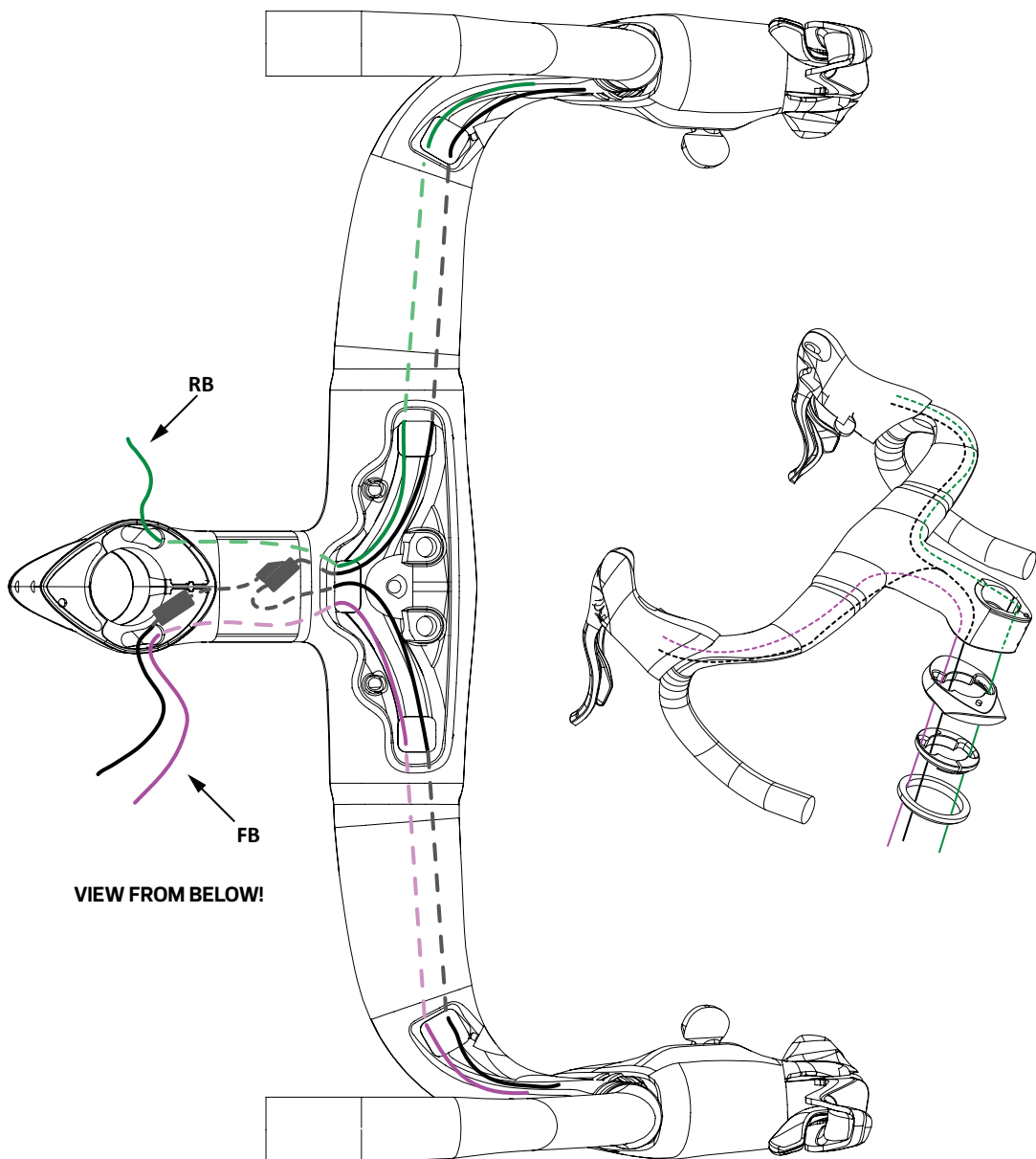

ATTENTION! The stem exit hole on the left-hand side the FB hose must be in front of the Di2 wire.

11. BRAKE CABLE INSTALLATION (INTEGRATED HANDLEBAR)

- 11.1.4 Connect RB and FB hose at the levers following OEM specs.
- 11.1.5 Install the closed rubber plug into the Talon ULTRA plastic cover.
- 11.1.6 Fix the cover to the handlebar with four screws. For the correct tightening torques, refer to the chart of the chapter "3. TOOLS AND TORQUE SPECS".

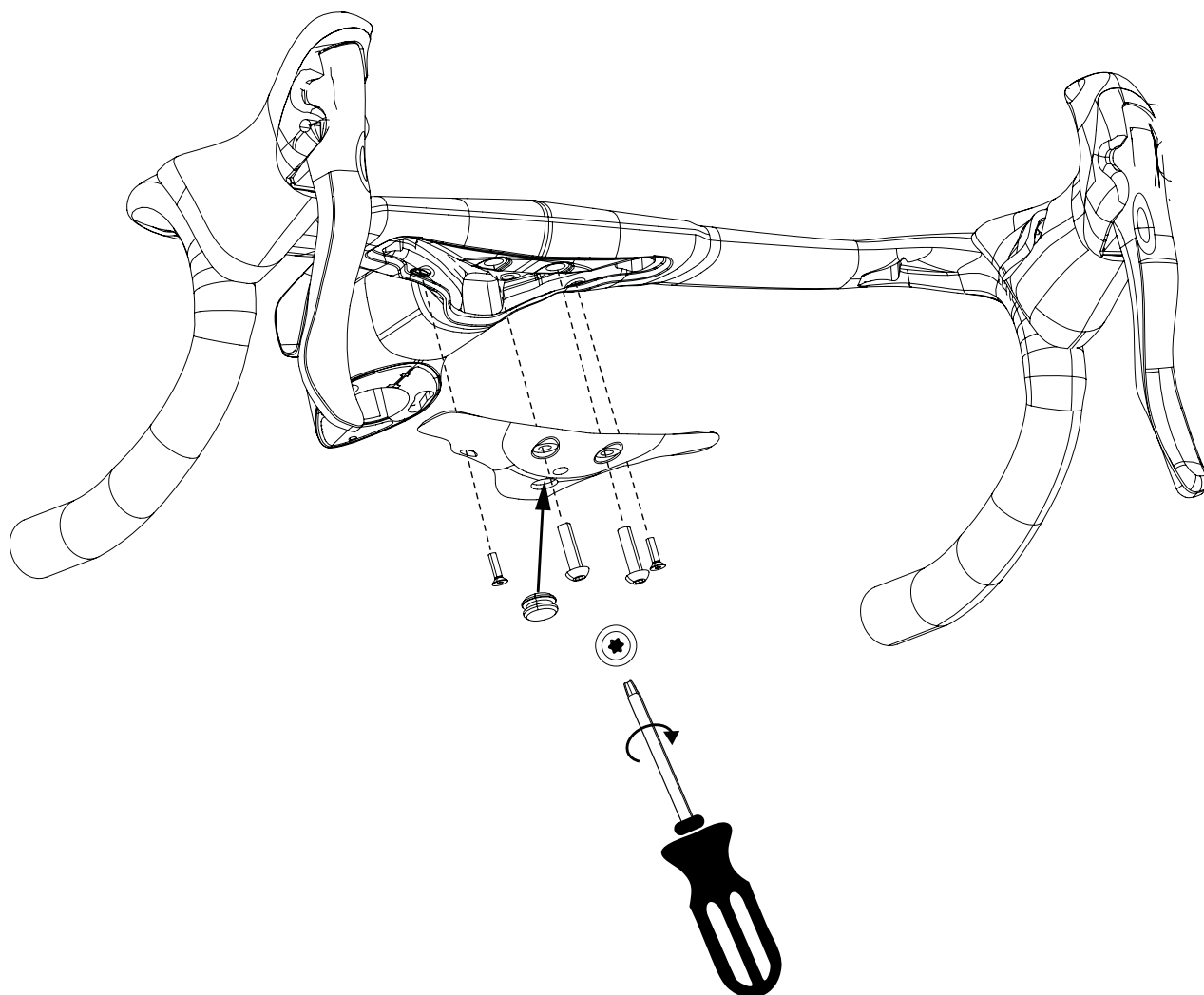

11. BRAKE CABLE INSTALLATION (INTEGRATED HANDLEBAR)

11.4 DISC & MECHANICAL

Steps that must be followed before:

6. DISC BRAKE: INSTALLATION AND HOSE ROUTING

8. MECHANICAL GROUPSET INSTALLATION

10. INTEGRATED HANDLEBAR (Talon ULTRA) ROUTING (Mechanical)

Follow steps 11.3.1 and 11.3.2 as before.

11.1.4 The handlebar cable routing looks like this:

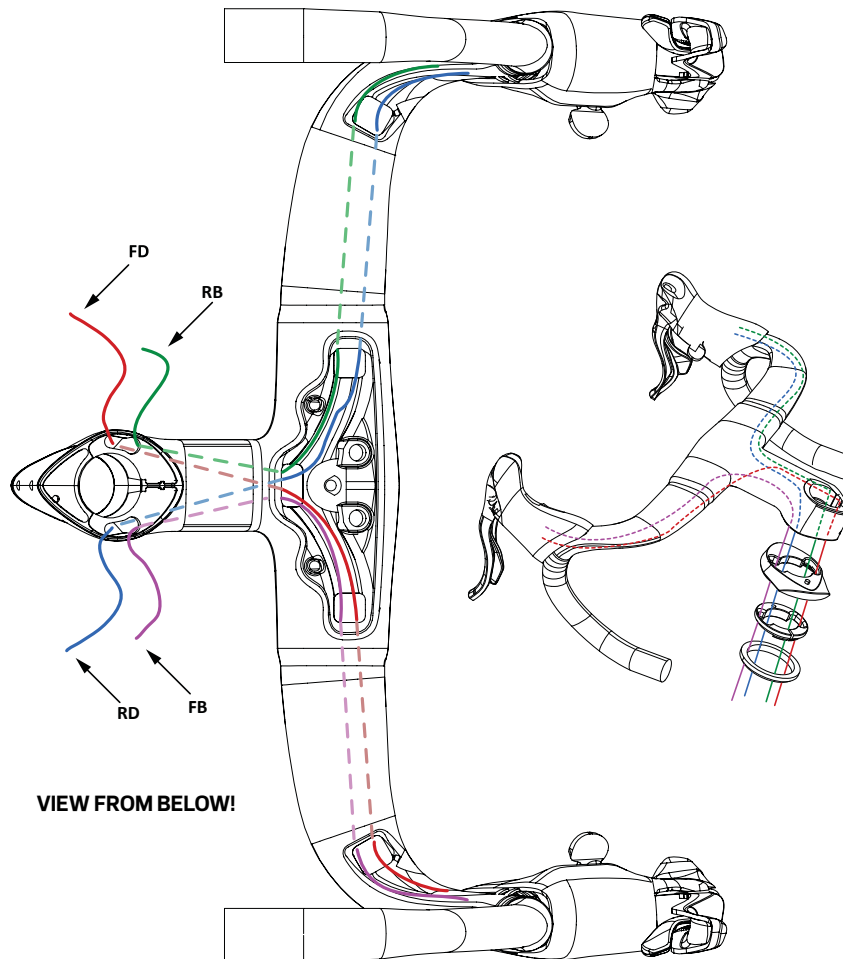

ATTENTION! The stem exit hole on the right-hand side the RB hose must be in front of the FD housing.

ATTENTION! The stem exit hole on the left-hand side the FB hose must be in front of the RD housing.

Follow steps 11.3.4, 11.3.5, 11.3.6 as before.

12. HEADSET ADJUSTING

12.1 Handlebar stack can be adjusted using the split spacers by 10mm and/or by 5mm.

12.2 Interlock, as illustrated below, the required number of spacers between top cap and the handlebar. Be careful that spacers and top cap have pins for alignment. Make sure that all cables are well positioned into the proper notch and they are not twisted around each other.

ATTENTION: see the below specifications about the maximum spacer heights allowed.

- 50 mm (e.g. 5 x 10mm spacers): when using the lower top cap (9mm)
- 40 mm (e.g. 4 x 10mm spacer): when using the medium top cap (19mm)
- 30 mm (e.g. 3 x 10 mm spacer): when using the higher top cap (29mm)

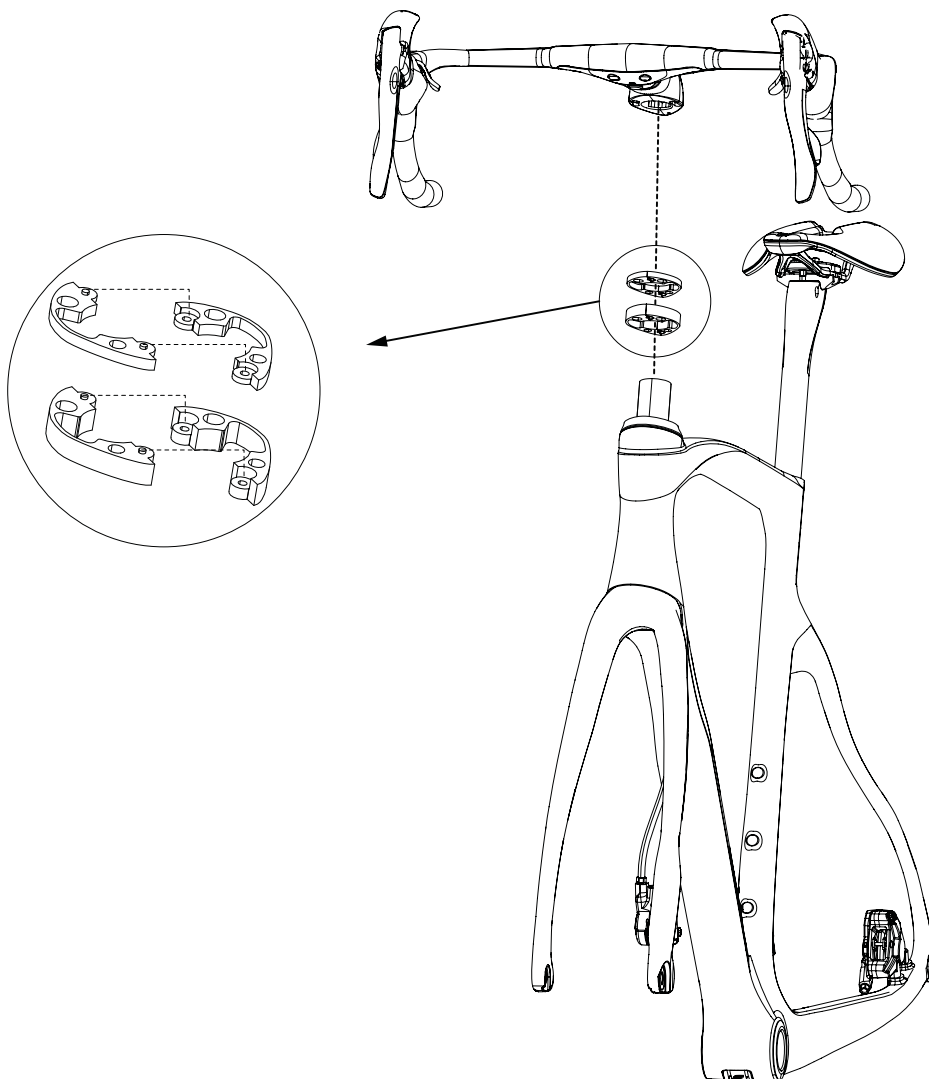

12. HEADSET ADJUSTING

ATTENTION! The following paragraphs refer to the cutting process of the steering tube, if you don't need to cut the steering tube, go straightly to the paragraph 12.7.

- 12.3** Install the number of spacers previously planned (see paragraph 9.4 or 10.3) between the handlebar and the top cap. Slide the handlebar down the steerer tube, until it and the spacers are firmly seated on the top cap. Slightly tighten the handlebar in order to keep all headset components in place.
- 12.4** Mark a line on the steerer tube in correspondence with the top edge of the stem.

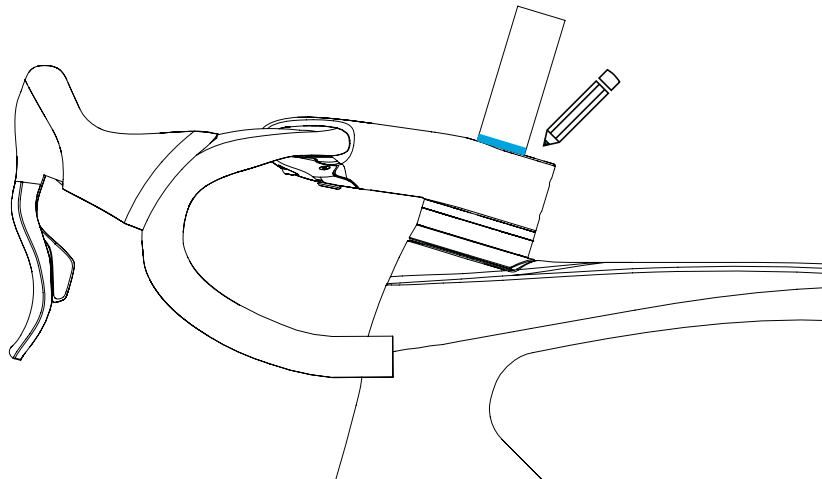

If you intend to leave the steerer tube longer above the stem (in order to maintain the possibility to rise the handlebar at a later date), place the desired number of standard aero spacers (not split) above the stem, as illustrated below, and mark a line just as described along the top edge of the upper spacer.

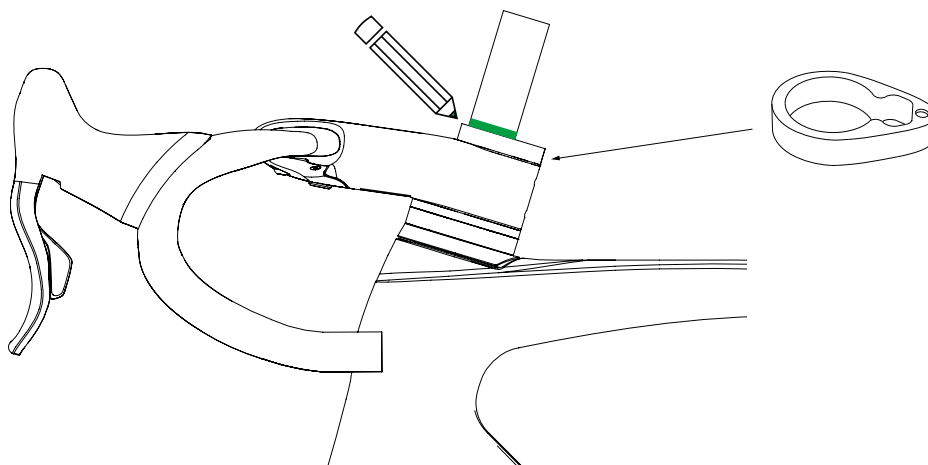

12. HEADSET ADJUSTING

12.5 Disassemble the handlebar and the spacers from the steerer tube.

12.6 Now you can cut the steerer tube.

ATTENTION! the actual cutting line must be 5 mm below the line made in the previous paragraph 12.4.

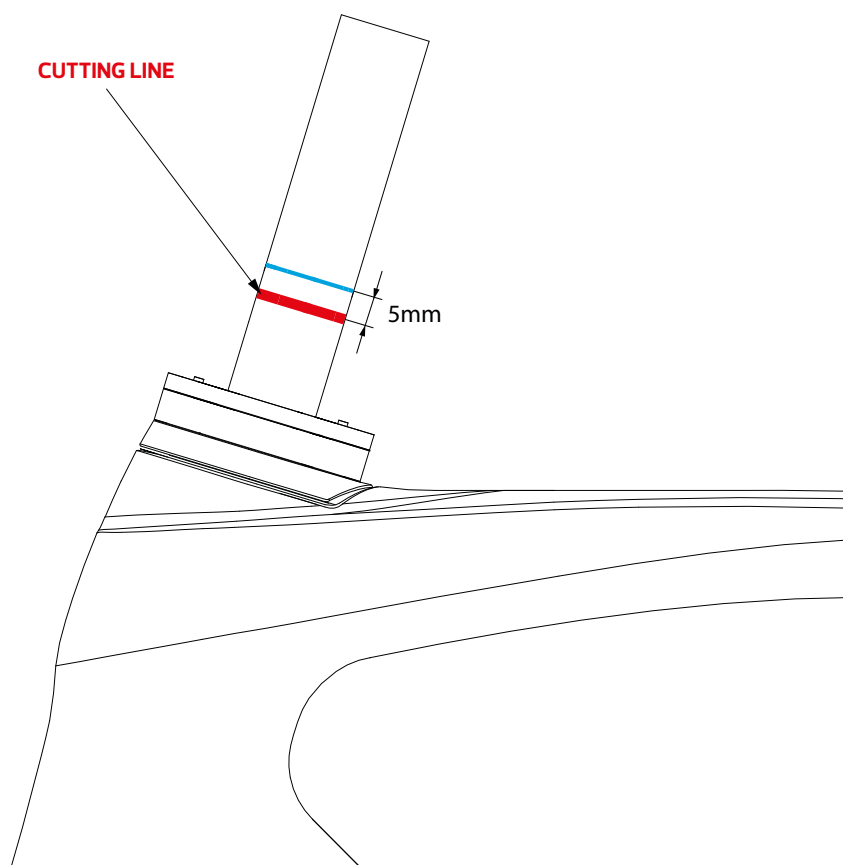

12. HEADSET ADJUSTING

- 12.7** Slide the handlebar down along the steerer tube till the top of the last spacer. Make sure to slightly push all housings back into the frame to avoid kinks. Firmly tighten the head set as usual, placing the expander and the top cover. For the correct tightening torques refer to the chapter "3. TOOLS AND TORQUE SPECS". The aspect of the rightly assembled headset should be like that showed below.

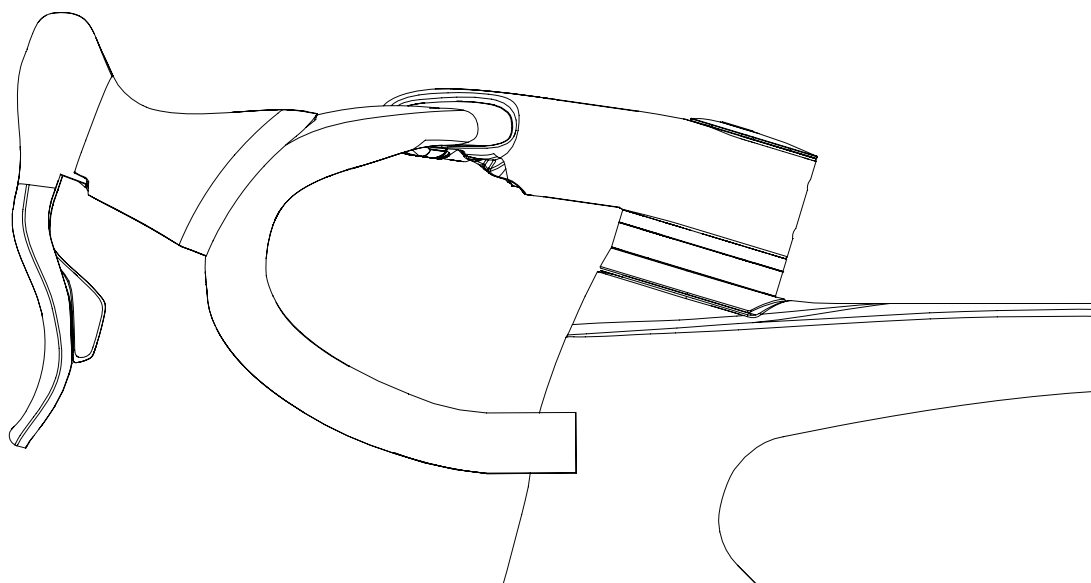

ATTENTION! The split spacers have larger dimensions than usual because of having to fit with the 1" ½ upper bearing. So, they cannot be used on the upper side of the handlebar. For the upper side, the standard aero spacers must be used (see also paragraph 12.4).

13. STEM AND BAR INSTALLATION AND ROUTING (FOUR CONFIGURATIONS)

- 13.1** The Dogma F12 and F12 Disk can be assembled also with the MOST TIGER stems and traditional bars. To allow the cables route into the frame a Top Cap Adapter is needed.
- 13.2** In order to perform the correct assembly of the bike with the stem and bar, you can follow the steps of the previous chapters with consideration for in this case there is the adapter between the stem and the spacers (and the top cap). Hence, positioning the stem (and bar) as already illustrated at paragraph 9.4 or 10.3; be careful to place in contact the handlebar and the adapter, and then the $X + 2$ cm dimension now needs to be considered from the lower planar surface of the adapter and upper planar surface of the top cap. Where X is total height of the spacers you are going to install.

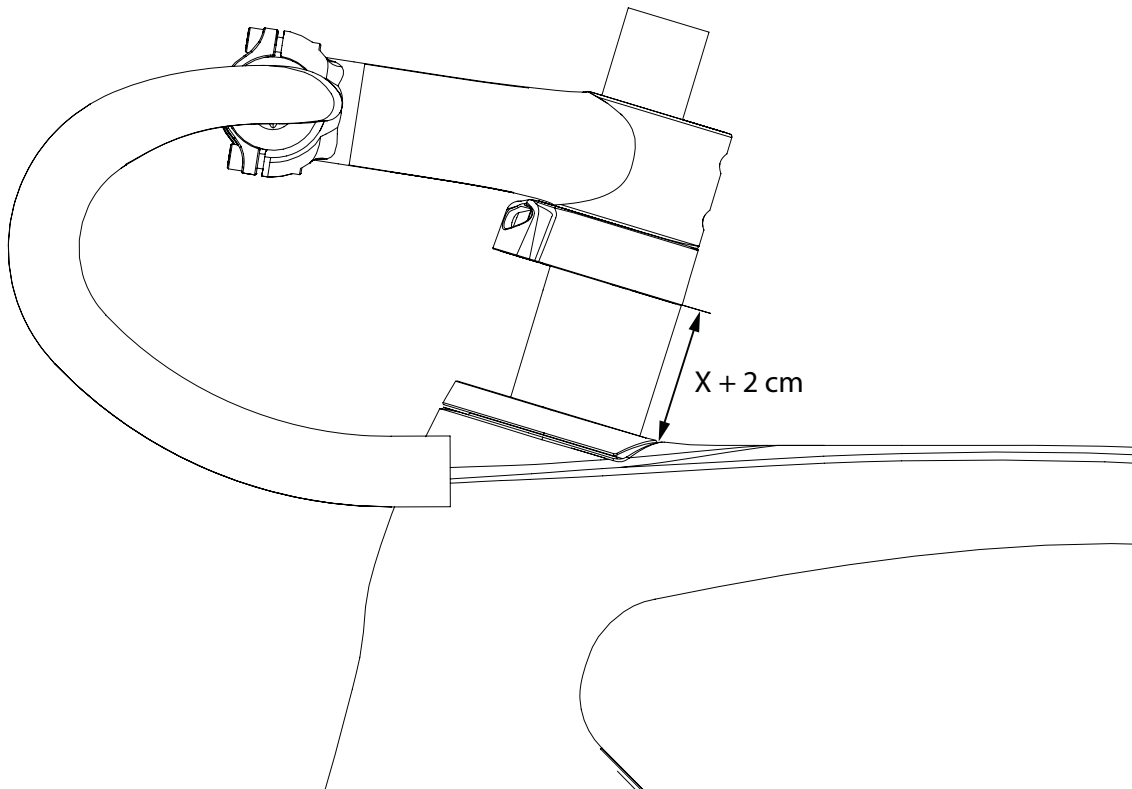

[where X is the total height of the spacers]

13. STEM AND BAR INSTALLATION AND ROUTING (FOUR CONFIGURATIONS)

- 13.3** The adoption of the adapter modifies the maximum spacer heights allowed. We must now take into consideration that the adapter height is 20 mm, so as a consequence:
- 30 mm (e.g. 3 x 10mm spacers): when using the adapter (20 mm) and the lower top cap (9mm)
 - 20 mm (e. g. 2 x 10mm spacer): when using the adapter (20 mm) and the medium top cap (19mm)
 - 10 mm (e. g. 1 x 10 mm spacer): when using the adapter (20 mm) and the higher top cap (29mm)

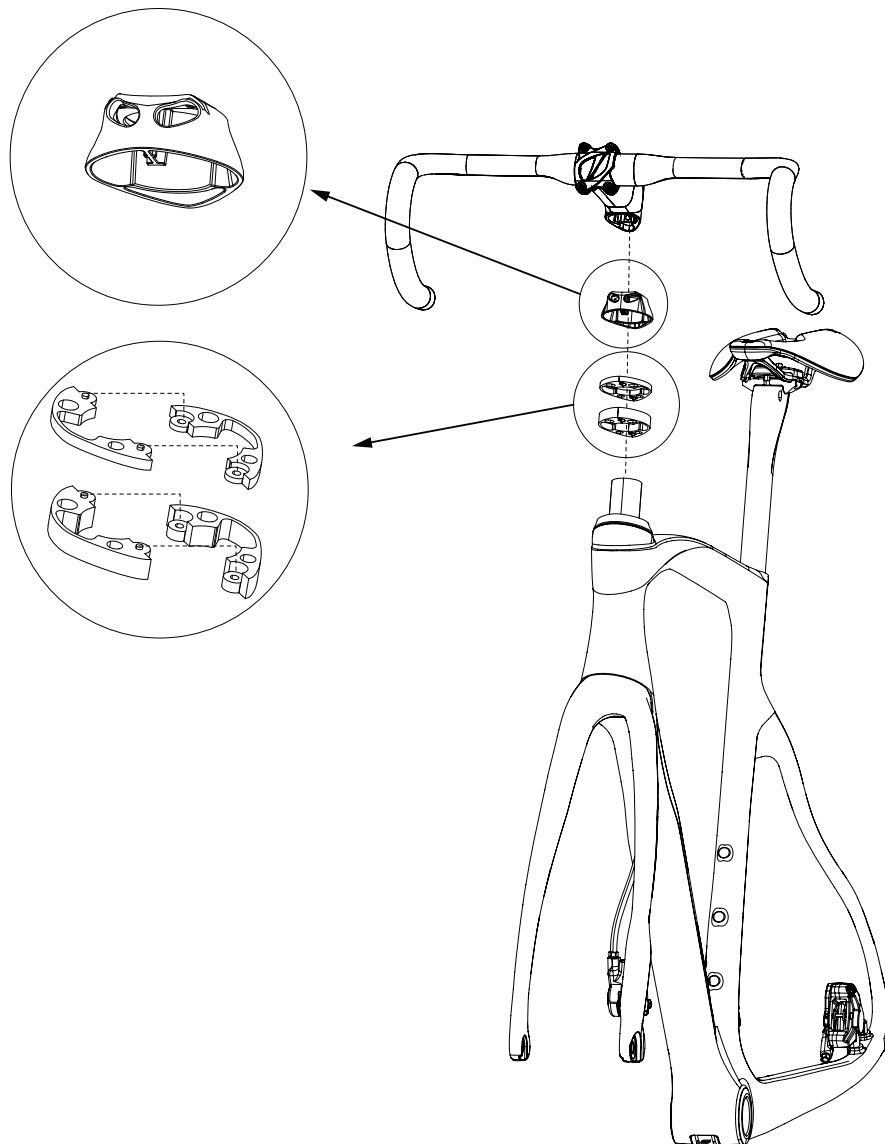

13. STEM AND BAR INSTALLATION AND ROUTING (FOUR CONFIGURATIONS)

13.4 Route the cables and/or housings following the instructions of the previous chapters. Refer to the table below for the correct routing through the adapter and around the steering tube.

	Left hand side (front)	Left hand side (back)	Right hand side (front)	Left hand side (back)
Rim & Electronic	Electronic wire	/	RB Housing	/
Rim & Mechanical	RD Housing	/	FD Housing	RB Housing
Disc & Electronic	FB Hose	Electronic wire	RB Hose	/
Disc & Mechanical	FB Hose	RD Housing	RB Hose	FD Housing

13.5 Tighten the headset as described in the previous chapter “12. HEADSET ADJUSTING”. If you need to cut the fork first, again refer to the previous chapter.
ATTENTION! Make sure to install the spacers always between top cap and adapter.

14. FINAL CHECKS

- 14.1** Final tightening of the brakes checking their correct centering (both disc and rim versions, front and rear), follow the OEM instructions.
ATTENTION! Disc brake calipers are provided loosen, make sure to tighten them following OEM specs before first ride.
ATTENTION! Make also sure that the disc brakes are properly bled (following OEM specs) before first ride.
- 14.2** Fine tune the drivetrain (both rear and front derailleur) following OEM specs.
- 14.3** Before first ride check carefully the correct assembly and operation of all components, repeat these controls periodically.



Cicli Pinarello SRL
Viale della Repubblica 12
31020 Villorba (TV) Italy
tel. +39 0422 42 08 77 fax +39 0422 42 18 16
infobike@pinarello.com
www.pinarello.com